



# Electric Service Guidelines

Revised April 1, 2024

# MTE's Electrical Service Guidelines

---

## TABLE OF CONTENTS

Changes in this Edition	3
Requirements and Service Conductor	4
General Metering Requirements	5
Metering Visual Screening	6
Right-of-Way Clearance Guide	7
ESG-400: 400 Amp Residential Metering	8
LBL-MDMB: Labeling for Multi-Metered Installations	9
Approved Vendors for Meter Base Tagging	10
ESG-1: Overhead Residential Service	11
ESG-2: Underground Residential Service	12
ESG-3: Underground Residential Service, Pad-Mount Transformer	13
ESG-4: Additional Meter on House	14
ESG-5: Member Pole Service (Municipal Purpose Only)	15
ESG-6: Overhead Temporary Service	16
ESG-7: Underground Temporary Service	17
ESG-9: Double Throw Switch Configuration of MTEMC Service and Standby Generator	18
ESG-10: Generlink Meter Collar	19
ESG-11 All Weather Road	20
FSMC-2: Free Standing Meter Center	21
FSMC-3: Meter Pedestal	22
FSMC-4: Free Standing Meter Center	23
COM-6: Non-Residential Metering with Multiple Customers and Service Laterals from a Single Transformer	24
Meter Troughs and Termination Enclosures (Tap Boxes)	25
1S: Secondary Ditch Detail	26
2S: Secondary Ditch Detail	27
CTE-1: Current Transformer Enclosure Specifications	28
MTE Office Locations	29

# **MTE's Electrical Service Guidelines**

---

## **Changes in this Edition 4/1/2024**

<b>FSMC-2</b>	Added overhead view of conduits for takeoff pole and post cap requirements.
<b>FSMC-3</b>	Added overhead view of conduits for takeoff pole.
<b>FSMC-4</b>	Added overhead view of conduits for takeoff pole.
<b>1S</b>	Updated ditch depth requirements.
<b>2S</b>	Updated ditch depth requirements.
<b>MTE Office Locations</b>	Updated Address for Murfreesboro Office

# MTEMC Requirements

## Installation

In addition to the National Electrical Code, National Electrical Safety Code, and state and local building codes, MTE has installation requirements which must be followed.

Please check with an MTE engineer or representative before locating the meter base or if you have questions about requirements or specifications.

### General Specifications

- A. Overhead Residential Services:
  - 1. Where a MTE engineering representative specifies an eyebolt for service attachment, install the eyebolt at a point lower than the weatherhead as required by NEC 230.54 (C), and no more than 18" horizontally from the weatherhead.
  - 2. Where a MTE engineering representative specifies a service mast for service attachments, install 2 1/2 inch rigid metal or IMC conduit fastened with a minimum of 2 mast clamps bolted through the wall on all residential services.
  - 3. In no case shall a residential point of attachment be less than 12 ft.
  - 4. All services must comply with Codes requirements for clearance. Codes can require more than 12' of clearance in many situations. MTE's engineering representative will assist in determining the required clearance.
  - 5. See ESG-1 for additional specification details.
- B. Overhead Non-Residential Services:
  - 1. Where a MTE engineering representative specifies an eyebolt for service attachment, install the eyebolt at a point lower than the weatherhead and no more than 18" horizontally from the weatherhead.
  - 2. Where a MTE engineering representative specifies a service mast for service attachments, install 2 1/2 inch rigid metal or IMC conduit fastened with a minimum of 2 mast clamps bolted through the wall on all residential services.
  - 3. All services must comply with Codes requirements for clearance.
  - 4. The MTE Service conductor must maintain a minimum 16 ft. ground clearance on all non-residential service lines. See an MTE engineering representative to confirm that the proposed point of attachment height will achieve sufficient ground clearance. If the point of attachment does not comply with the clearance requirements, MTE will not energize the service.
  - 5. See ESG-1 for additional specification details.
- C. Underground Services: See ESG-2 or ESG-3 for specification details. See drawings 1S and 2S for the secondary ditch details. See the General Service Conductor section at the bottom of the page.
- D. Manufactured and Modular Home Services:
  - 1. A **red** HUD label identifies **manufactured** or **mobile** homes. Meters may not be installed on manufactured or mobile homes. See ESG-4 or ESG-5 for specification details.
  - 2. **Modular** homes are identified by a **green** State of Tennessee label. Services for modular homes may be identical to overhead or underground residential services. See ESG-1, ESG-2, or ESG-3 for specification details.
- E. Temporary Services:
  - 1. Overhead - Temporary service pole must be within 125 ft. of MTE pole. See ESG-6 for specification details
  - 2. Underground - Temporary service pole must be located behind right corner of pad mount transformer or underground secondary box. See ESG-7 for specification details.
- F. Meter on MTE's Pole: MTE no longer allows standard meter installations on MTE poles. When a MTE pole is changed out, any meters on MTE's poles shall be removed if possible. Meters on poles for communication companies may be transferred to new poles as necessary. Instrument rated meters are allowed on MTE owned poles.
- G. Point of Demarcation: The point of demarcation, as designated by MTE, is the point on the customer's premises where current is to be delivered to a building or premises. All wiring and equipment, except for the meter, beyond this point of demarcation shall be provided and maintained by the customer.

## GENERAL SERVICE CONDUCTOR

Underground service conductors installed near other utility lines, structures, or obstructions have minimum separation requirements. Please see MTE's *Underground Installation Guide* for the required clearances.

# GENERAL METERING REQUIREMENTS

## Non Residential- anything other than a single family dwelling

1. All meter sockets used in MTEMC's service area must be one of the MTEMC approved meter sockets (bases). All sockets and hubs shall be furnished and installed by the member.
2. All meter sockets must be mounted between 4 and 6 feet above final grade. If physical space available requires that meter bases be installed in a vertical arrangement, the highest meter shall be not more than six (6) feet above the floor to the center of the glass cover, and the lowest meter shall not be less than three (3) feet from the floor to the center of the glass cover.
3. All meter sockets shall be mounted outdoors in a location that is easily accessible for MTEMC personnel. Any variation must be approved in writing by a MTEMC engineering representative.
4. The maximum allowable service wire to connect to MTEMC padmount transformer is 750MCM. The maximum allowable service wire to connect in UG pull box is 500 MCM. For single phase services of 800 amps or less, MTEMC will pull the service wire from the transformer/pull box to the metering point. For multi-family single phase services of 2000 amps or less, MTEMC will pull the service wire from the transformer/pull box to the metering point.
5. All three phase services shall have a solid neutral wire running from the transformer to the meter base regardless of connection type.
6. For all 277/480 V self-contained services feeding from a transformer, a non-fuseable safety switch or breaker with provisions for an MTE padlock shall be installed on the source side of the meter base.
7. For all 120/208 and 120/240V self-contained & any instrument rated metering installations shall require a disconnect on the load side of the meter on the exterior of the building.
8. If more than one building is fed from the same transformer, a disconnect shall be installed on the source side of all Tap boxes and ganged metering installations.
9. If a service conductor feeds several meters (gang meter socket, metering trough, etc.), each meter, disconnect, and main electrical panel inside each unit shall be labeled with identification numbers (address). These numbers shall be on a stamped or engraved brass or stainless-steel label and attached with 2 or more rivets. They should be in a readily visible location on both the meter and disconnect. Labels shall be furnished and installed by the customer.

## Residential- single family dwelling

1. All meter sockets used in MTEMC's service area must be one of the MTEMC approved meter sockets (bases). All sockets and hubs shall be furnished and installed by the member.
2. All meter sockets must be mounted between 4 and 6 feet above final grade.
3. All meter sockets shall be mounted outdoors in a location that is easily accessible for MTEMC personnel. Any variation must be approved in writing by a MTEMC engineering representative.
4. The maximum allowable service wire to connect to MTEMC padmount transformer is 750MCM. The maximum allowable service wire to connect in UG pull box is 500 MCM. For single phase services of 800 amps or less, MTEMC will pull the service wire from the transformer/pull box to the metering point.
5. Meter base will not be located on or under porches, decks or carports. The meter base shall be located as close to MTEMC's transformer/pull box as possible. If the distribution panel is not located in immediate vicinity of meter, a weatherproof disconnect may be required; refer to National Electric Code.
6. A **grounding electrode conductor (ground wire)** of a minimum of No. 4 copper or larger shall be run unspliced from a lug in the meter base to a driven **grounding electrode (ground rod)**.  
An 8 ft. driven **grounding electrode (ground rod)** bonded to **grounding electrode conductor (ground wire)** with clamp suitable for direct soil burial will be installed below final grade.

# METERING VISUAL SCREENING

---

## ELECTRICAL METER ROOMS WILL NOT BE ALLOWED

### SHIELDING THE VIEW OF METERS

Shielding the view of meters with walls is allowed with written approval of MTEMC. This must be obtained PRIOR TO CONSTRUCTION.

A drawing showing the physical arrangement of all meters must be provided to MTEMC prior to obtaining approval.

If physical space available requires that meter bases be installed in a vertical arrangement, the highest meter shall be not more than six (6) feet above the floor to the center of the glass cover, and the lowest meter shall not be less than three (3) feet from the floor to the center of the glass cover.

The meters shall be located where they will be readily accessible at ALL times for emergencies, meter reading, testing and other maintenance purposes. All meter locations shall meet all NEC requirements regarding but not limited to access, egress and clear space around the meter. There shall be a minimum of three and one half (3.5) feet working space between the front of the meter socket and any walls or other obstructions. The meters shall be located on an exterior wall of the building.

There shall be no roof covering the meter space. There shall be no door, gate, etc. at the entry of the space.

Access is a critical issue for MTEMC related to its facilities. If access to the meter space is not possible due to some obstruction, MTEMC reserves the right to remove the obstruction and is not responsible for any damages to those or for reinstalling them in the future.

Meter spaces shall not be used for other purposes such as storage closets, maintenance areas, etc.

Meter bases shall be surface mounted. Flush mounted or recessed meter installations are not acceptable.

If the acceptance of a meter space by MTEMC requires additional communication infrastructure related to the reading of the meters by the MTEMC AMI system, the additional costs will be the responsibility of the customer.

## Right-of-Way Clearance Guide

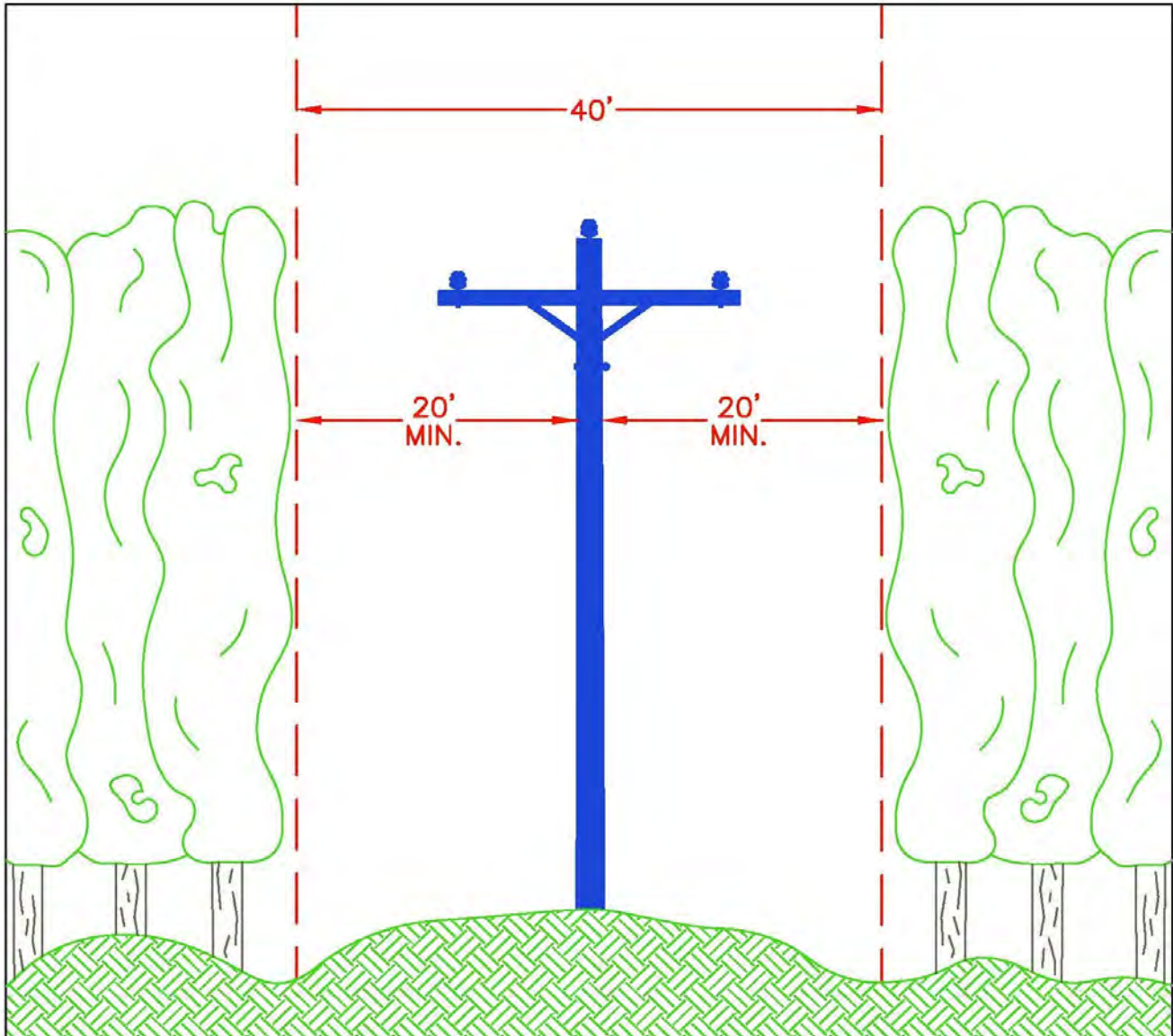

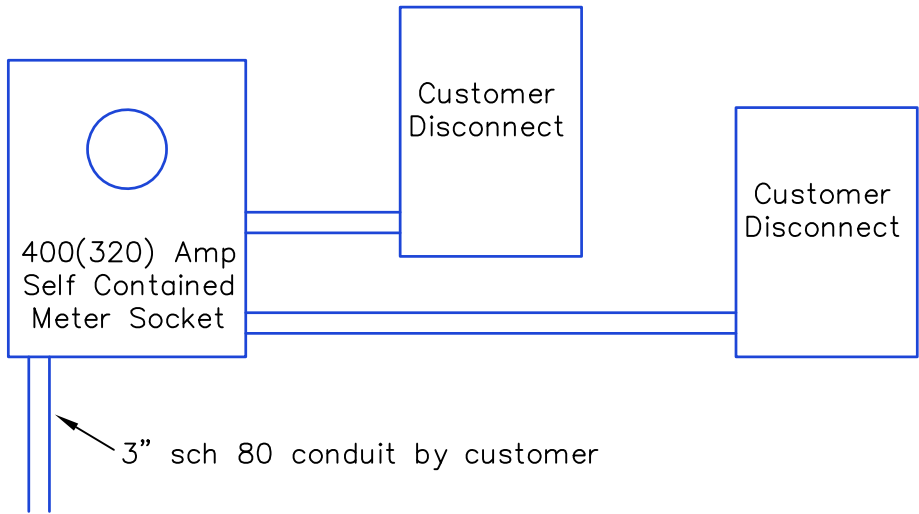

MTE PREFERRED METHOD

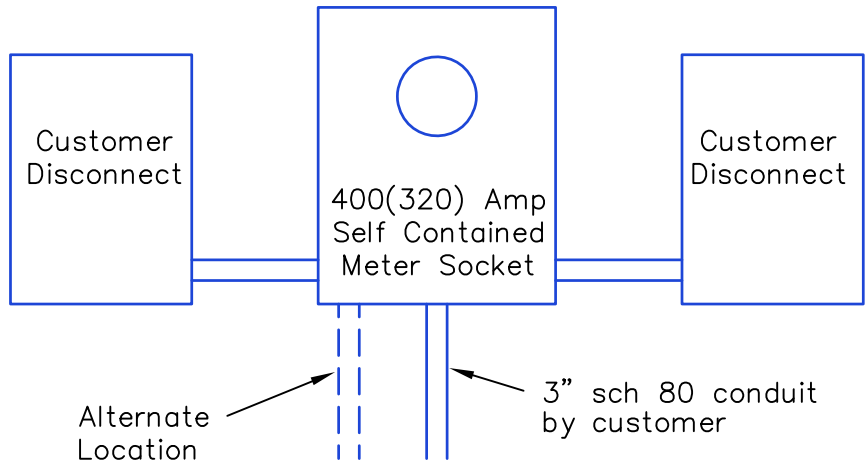

MTE ALTERNATE METHOD

**NOTE: SEE MTE ENGINEERING REPRESENTATIVE FOR APPROVAL**



400 AMP  
RESIDENTIAL  
METERING

(WHEN DISCONNECTS ARE REQUIRED)

DRAWING NUMBER:

ESG-400

REVISED DATE:

OCT. 5, 2016

SCALE: NONE

SHEET: 1 OF 1



**Fig. 1 (GANG METER)**

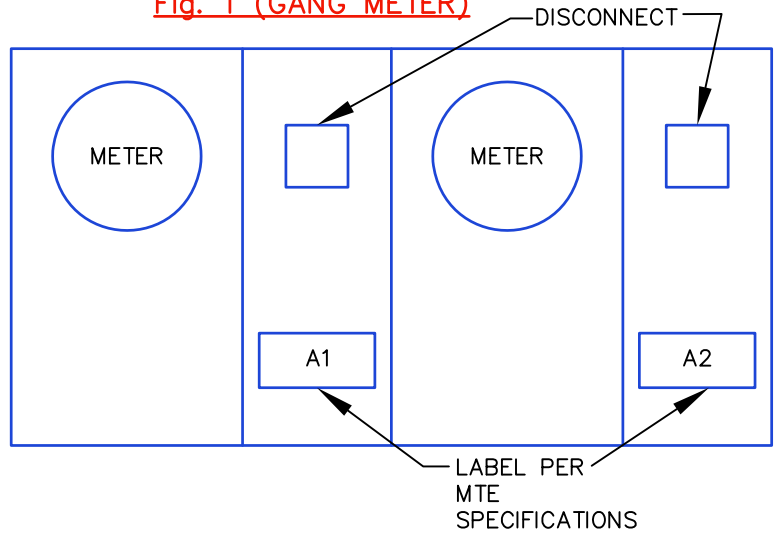

**Fig. 2 (TAP BOX METERS)**

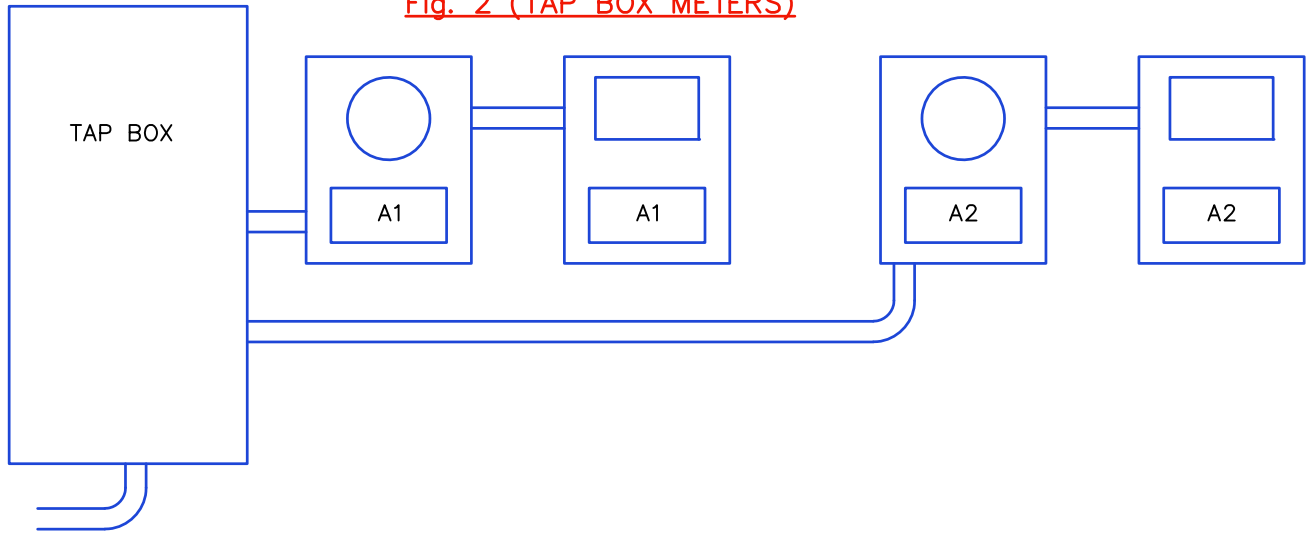

MIDDLE TENNESSEE ELECTRIC REQUIRES ALL LABELING ON METER SOCKETS TO MEET THE FOLLOWING SPECIFICATIONS:

1. ALL LABELS SHALL BE SOLID BRASS RATED FOR OUTDOOR USE OR STAINLESS STEEL, MINIMUM SIZE IS 1" X 3".
2. IDENTIFICATION NUMBERS AND LETTERS SHALL BE STAMPED OR ENGRAVED.
3. PERMANENT LABELS SHALL BE FASTENED WITH RIVETS.
4. FOR GANG METER SOCKETS, LABEL SHALL BE PLACED ON ALL OF THE DISCONNECT PORTIONS OF THE METER BASE (SEE FIG. 1).
5. FOR TAP BOX APPLICATIONS, LABEL SHALL BE PLACED IN A READILY VISIBLE LOCATION FOR BOTH THE DISCONNECT AND THE METER COVER (SEE FIG. 2).
6. THE MAIN ELECTRICAL PANEL INSIDE EACH UNIT SHALL BE MARKED WITH THE CORRESPONDING UNIT NUMBER. THE MARKING SHALL BE PERMANENT IN NATURE, WITH THE IDENTIFYING LABEL AFFIXED INSIDE THE PANEL.
7. THE MAIN ENTRY DOOR TO THE UNIT SHALL BE MARKED WITH IDENTIFYING LABEL AFFIXED TO THE DOOR OR AREA ADJACENT TO THE ENTRANCE IN PLAIN VIEW.
8. METERS WILL NOT BE SET AND ENERGIZED UNTIL ALL LABELING IS COMPLETED FOR THE CORRESPONDING SERVICE PULL.
9. REFER TO "METER TROUGHS AND TERMINATION ENCLOSURES" FOR ADDITIONAL SERVICE REQUIREMENTS.
10. SEE "APPROVED VENDORS FOR METER BASE TAGGING".
11. MULTIPLE FAMILY UNITS REQUIRE THE MINIMUM CONDUIT REQUIREMENTS:
  - TOWNHOMES:
    - UP TO 5 UNITS – ONE (1) 3" CONDUIT TO THE GANG BASE
    - 6 UNITS OR LARGER – TWO (2) 3" CONDUITS TO THE GANG BASE
  - APARTMENTS:
    - 1 TO 11 UNITS – ONE (1) 3" CONDUIT TO EACH GANG BASE
    - 12 TO 36 UNITS – TWO (2) 3" CONDUITS TO EACH GANG BASE
    - TWO (2) 3" CONDUITS FOR ALL ROAD CROSSINGS

	
<p><b>LABELING FOR MULTI-METERED INSTALLATIONS</b></p>	
<p><b>DRAWING NUMBER:</b></p> <p style="font-size: 24pt; font-weight: bold;">LBL-MDMB</p>	<p><b>REVISED DATE:</b></p> <p style="font-weight: bold;">OCT. 2, 2023</p>
<p><b>SCALE:</b> <u>  NONE  </u></p>	
<p><b>SHEET:</b> <u>  1  </u> OF <u>  1  </u></p>	

# Approved Vendors for Meter base Tagging

Amplify Awards & Gifting  
1113 Murfreesboro RD #412  
Franklin, TN 37064  
(615) 794-8479

L & K Trophy House  
1115 Memorial Blvd  
Murfreesboro, TN  
(615) 893-0547

B & B Awards & Engraving  
1288 Dow St  
Murfreesboro, TN  
(615) 890-4780

Sports World  
535 W Baddour Pkwy  
Lebanon, TN 37087  
(615) 444-6554

Border States Elec.  
656 Wedgewood Ave.  
Nashville, TN 37202  
(615) 255-4161

Specialty Engraving  
P.O. box 131  
3042 York RD  
Pleasant View, TN 37146  
(615) 252-1952

Central Meter Lab  
331 N Front Street  
Murfreesboro, TN 37130  
(615) 890-7357

Team Electric  
949 North Thompson Ln  
Murfreesboro, TN 37129  
(615) 867-4895

City Electric  
961 New Salem Hwy  
Murfreesboro, TN 37129  
(615) 848-2022

Demented Tags  
509 N Graycroft Ave.  
Madison, TN 37115  
(615) 300-8186

E & J Engraving  
7766 Highway 100  
Bellevue, TN 37221  
(615) 405-0800

The Engraving Company  
150 Pewitt Drive  
Brentwood, TN 37027  
(615) 373-3662

# 225 amp or less

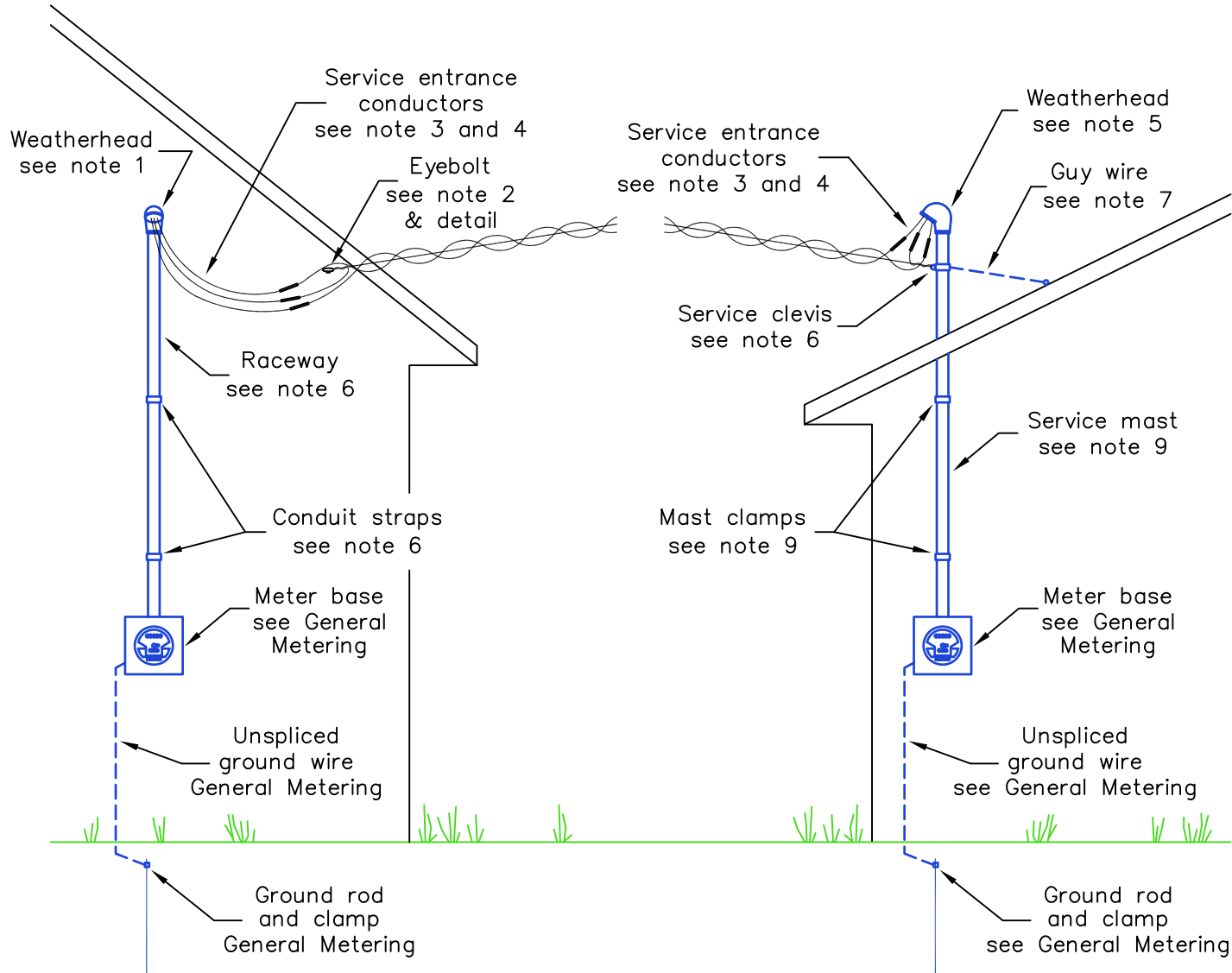

## Notes

1. Weatherhead must be above point of service drop attachment.
2. An eyebolt (5/8" minimum) and related hardware will be furnished and installed by the member. The eyebolt must pass through a plate consisting of two 2"x6"s doubled together similar to a window header spanning two or more wall studs and secured to the studs with a minimum of two four-inch lag screws in each end of the 2"x6" assembly. If the eyebolt is installed outside a finished wall, such that the nut and washer protruding past the doubled 2"x6"s into the interior of the structure will hinder finishing of the interior wall, the alternate method may be used. This consists of a single 2"x6" equal in length to a wall stud, turned 90 degrees, nailed to a wall stud along its entire length, and backed by an additional stud situated normally and nailed to the 90 degree 2"x6". The 2"x6" shall be nailed in with a minimum of 5 nails per side, with no more than 14" between nails along its length. This assembly will provide a cavity for the nut and washer assembly to clear the stud side of the interior wall wallboard. See "Alternate Eyebolt Detail".
3. Residence Clearance – The eyebolt must be below as required by NEC 230.54C and within 18 inches of weatherhead and minimum of 12 feet above final grade. Point of service drop attachment will be of sufficient height to provide minimum clearance as specified by the National Electric Code (NEC) and the National Electric Safety Code (NESC). If the area below the service drop has the ability to be accessed by trucks, farm equipment, or horses, the NESC requires 16'.
4. Non-Residence Clearance (detached buildings) – The eyebolt must be below as required by NEC 230.54C and within 18 inches of weatherhead and minimum of 16 feet above final grade. Point of service drop attachment will be of sufficient height to provide minimum clearance as specified by the National Electric Code (NEC) and the National Electric Safety Code (NESC). The NESC requires 16' to all non-residential buildings.
5. Service entrance conductor must extend 36" out of the weatherhead.
6. Rigid conduit, IMC, EMT, or SC. 40 electrical PVC with rain-tight couplings and connectors may be used as service entrance conductor raceway. Service entrance raceways will be secured with a minimum of 2 conduit straps, the lower being within 3 feet of top of meter base.
7. Where a mast riser is used, weatherhead will be a minimum of 36 in. above roof. If weatherhead is more than 42 inches above roof, a guy wire with eyebolt through rafter is required.
8. Service clevis assembly will be furnished and installed by MTE.
9. Service mast will be a minimum of 2 1/2" rigid metal conduit secured with a minimum of 2 mast clamps fastened to a structural part of the building (sheathing on a vinyl sided house is not sufficient) with 1/2" clamp bolts; the lower being within 3 feet of top of the meter base and the upper being within 3 feet of where the mast passes through the roof. Sections of conduit must be connected using threaded couplings, and the threaded coupling must be located between the clamps.
10. Service Location/ Point of Demarcation to be designated by MTE. See General Specifications part G of Installation requirements above for further information.
11. See General Metering Requirements for additional metering information

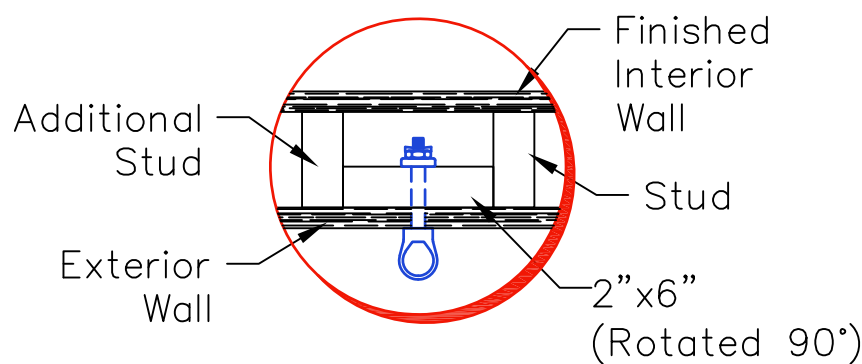

**ALTERNATE EYEBOLT DETAIL**

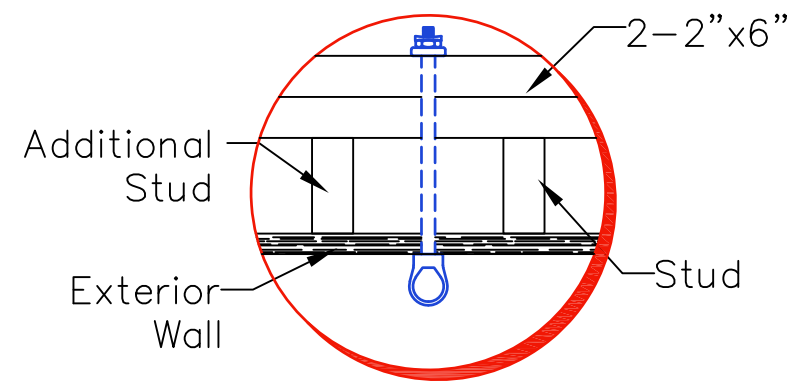

**PREFERRED EYEBOLT DETAIL**

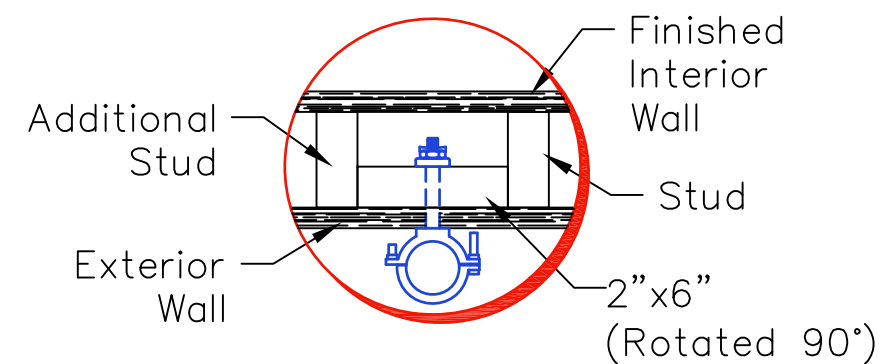

**MAST CLAMP DETAIL**



### OVERHEAD RESIDENTIAL SERVICE

DRAWING NUMBER:

ESG-1

REVISED DATE:  
OCT. 2, 2023

SCALE: NONE

SHEET: 1 OF 1

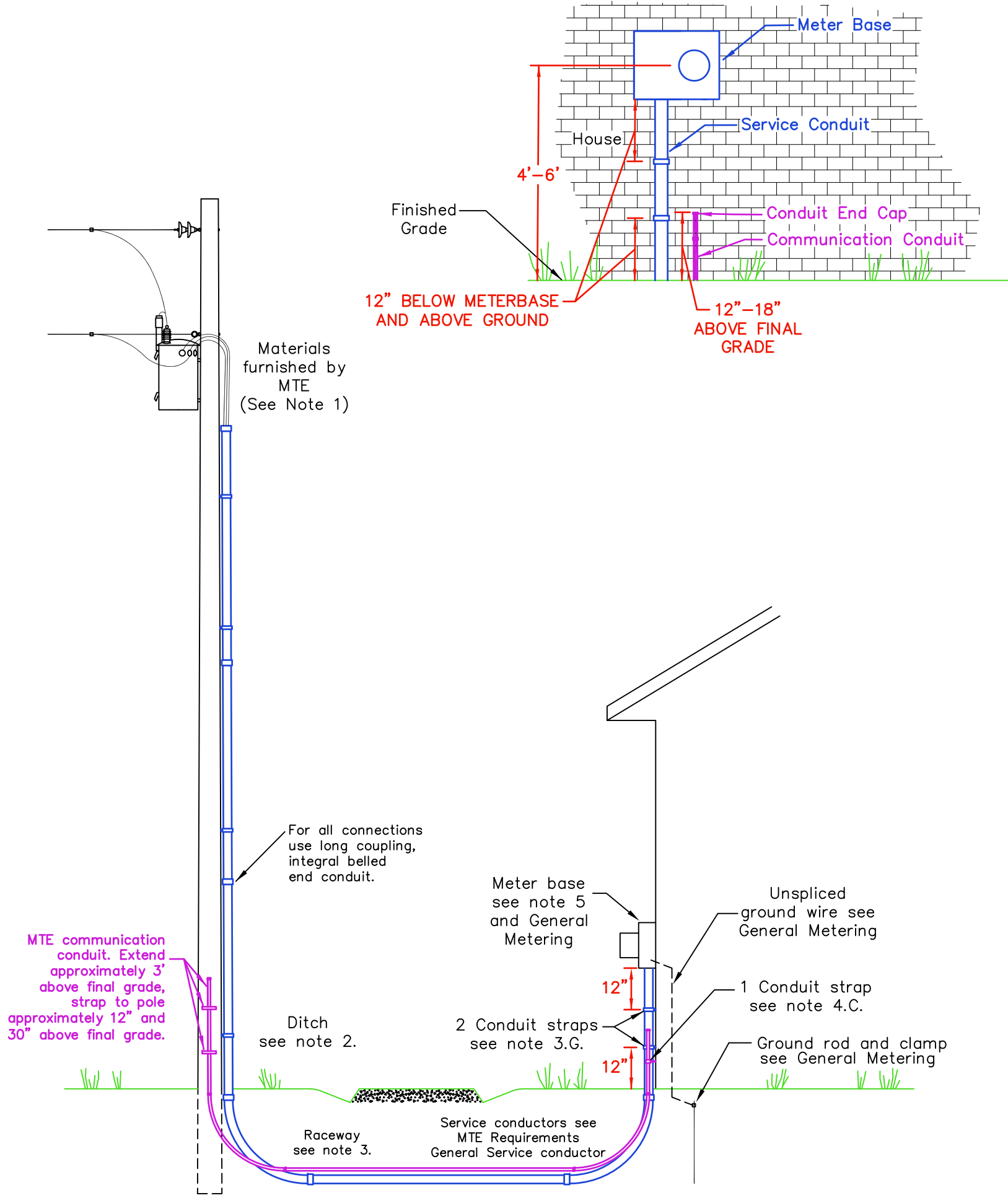

**Notes**

- \*Be sure to call Tennessee One Call before digging or opening ditches: 1-800-351-1111 or 811
- 1. MTE will furnish and install the following materials at the service pole:
  - A. Electrical conduit, to include all related hardware.
  - B. Service conductor from transformer to meter base.
  - C. Where junction box (not shown) is present at service pole, see a MTE engineering representative for specifications.
- 2. Member will open ditch from service pole or junction box to meter location with the following specifications:
  - A. Where ditch length will exceed 150 ft. see MTE engineering representative prior to opening ditch.
  - B. Depth sufficient to bed conduit with service conductors 24 in. below final grade.
  - C. Where impractical to obtain 24 in. depth, see a MTE engineering representative.
  - D. Member will backfill ditch after inspection by MTE - 24 hr. notice required (call 877-886-8362 or visit www.MTE.com to fill out an online request)
- 3. Continuous electrical raceway from service pole base to meter base will be furnished and installed by member to the following specifications:
  - A. Conduit size is to be 3 inch with appropriate fittings and/or bushings as required. For all conduit connections use long, (6" minimum) integral belled end conduit.
  - B. Raceway between elbows is to be schedule 40 electrical PVC or schedule 80 electrical PVC.
  - C. Elbows are to be schedule 80 electrical PVC with a minimum sweeping radius of 24 inches.
  - D. Conduit extending from meter base to one foot below grade is to be schedule 80 electrical PVC.
  - E. A polyvinyl, non rot or mildew proof, pull string with a minimum breaking strength of 200 pounds is to be installed inside the raceway.
  - F. Under certain loading and/or density conditions, an alternate sized conduit may be used with the approval of MTE district office engineering representative.
  - G. 2 Conduit Straps: Place one conduit strap 12" below meter base and place second conduit strap 12" above ground.
  - H. Conduit shall be placed on firm soil throughout the entire run. The bedding below the conduit near the meter base shall be sufficient to prevent settling. Should MTE deem bedding to be insufficient, a 3" PVC expansion coupling shall be required at the meter base. The expansion sleeve shall be located between the two conduit straps as referenced in Note 3G.
  - I. Service Location/ Point of Demarcation to be designated by MTE. See General Specifications part G of Installation requirements above for further information.
- 4. Continuous comm raceway from service pole to directly below the meter base will be furnished and installed by the member to the following specifications:
  - A. Conduit to be 1" gray PVC sch 40 or HDPE SDR 13.5, along with any appropriate fittings.
  - B. Conduit will run from approximately 3' above final grade at the pole to 12-18" above final grade below the meter.
  - C. Conduit shall be strapped to the pole approximately 12" and 30" above final grade and to house/structure approximately 6" below top of conduit. A minimum of 1/2" stainless steel straps shall be used.
  - D. Both ends of the conduit must have appropriate end caps installed with glue.
  - E. Under certain conditions, an alternative conduit may be used with the written approval of MTE Engineering.
  - F. Comm conduit should be installed in the same ditch as the electrical conduit. The comm conduit shall meet the same depth and bedding requirements as the electrical conduits.
  - G. A polyvinyl, non-rot or mildew proof, pull string with a minimum breaking strength of 200 pounds is to be installed in the raceway.
  - H. Install a comm flower pot at base of pole if more than one house will be served from pole.
- 5. A MTE approved meter base of proper size and type shall be furnished and installed by the member. See General Metering Requirements for additional metering information.

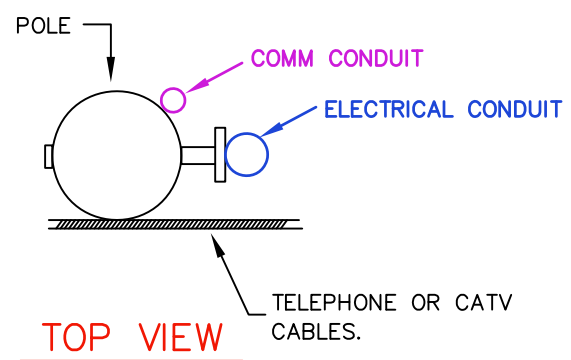

	
<b>UNDERGROUND RESIDENTIAL SERVICE</b>	
DRAWING NUMBER: <b>ESG-2</b>	REVISED DATE: OCT. 2, 2023
SCALE: <u>NONE</u>	
SHEET: <u>1</u> OF <u>1</u>	



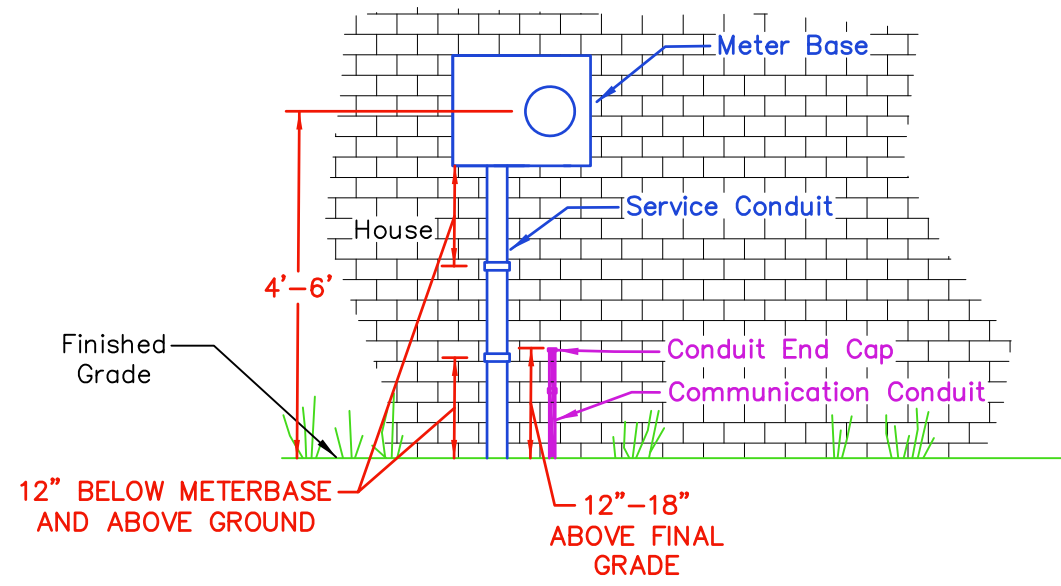

**Caution!**  
 Before digging, Call TN-1-CALL (1-800-351-1111 or 811) to determine location of underground facilities. Hand-dig ditch within 5 feet of transformer.

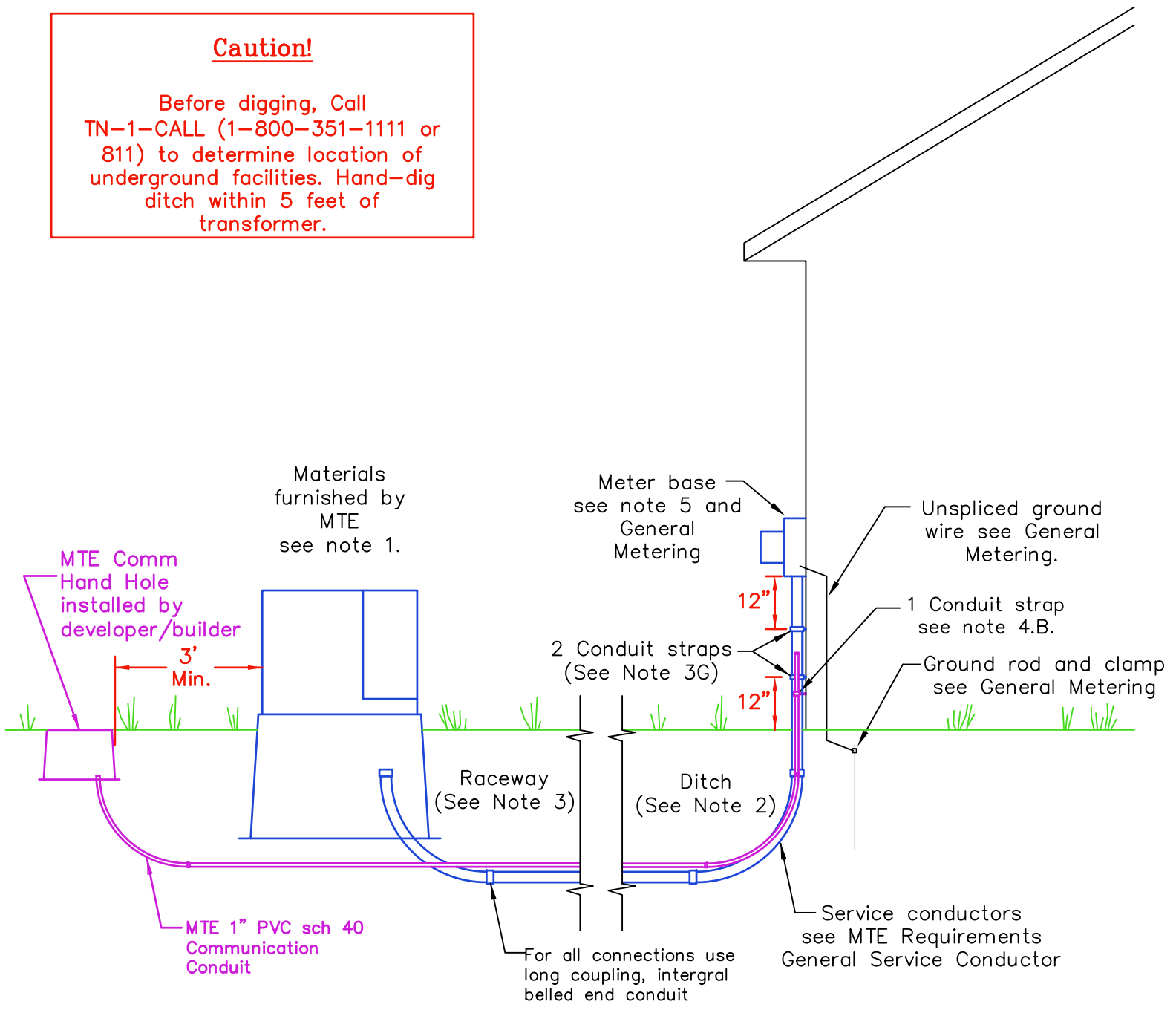

Notes:

\*Be sure to call Tennessee One Call before digging or opening ditches: 1-800-351-1111 or 811

1. MTE will furnish and install the following materials:
  - A. Service conductor from transformer to meter base
  - B. Where junction box (not shown) is present, see a MTE engineering representative for specifications.
2. Member will open ditch from transformer to meter location with the following specifications:
  - A. Where ditch length will exceed 150 ft. see a MTE engineering representative prior to opening ditch.
  - B. Hand-dig ditch when within 5 ft. of transformer.
  - C. Depth sufficient to bed conduit with service conductors 24 in. below final grade.
  - D. Where impractical to obtain 24 in. depth, see a MTE engineering representative.
  - E. Member will backfill ditch after inspection by MTE - 24 hr. notice required (call 877-886-8362 or visit www.MTE.com to fill out an online request)
  - F. Before working with the transformer, notify MTE so that MTE representation can be present.
3. Continuous electrical raceway from transformer to meter base will be furnished and installed by member to the following specifications:
  - A. Conduit size is to be 3 inch as specified below with appropriate fittings and/or bushings as required. For all conduit connections use long, (6" minimum) integral belled end conduit.
  - B. Raceway between elbows is to be either schedule 40 electrical PVC or schedule 80 electrical PVC conduit.
  - C. Elbows are to be schedule 80 electrical PVC with a minimum sweeping radius of 24 inches.
  - D. Conduit extending from meter base to one foot below grade is to be schedule 80 electrical PVC.
  - E. A polyvinyl, non-rot or mildew proof, pull string with a minimum breaking strength of 200 pounds is to be installed inside the raceway.
  - F. Under certain loading and/or density conditions, an alternate sized conduit may be used with the approval of MTE district office engineering representative.
  - G. 2 Conduit straps: Place one conduit strap 12" below meter base and place second strap 12" above ground.
  - H. Conduit shall be placed on firm soil throughout the entire run. The bedding below the conduit near the meter base shall be sufficient to prevent settling. Should MTE deem bedding to be insufficient, a 3" PVC expansion coupling shall be required at the meter base. The expansion sleeve shall be located between the two conduit straps as referenced in Note 3G.
  - I. Service Location/ Point of Demarcation to be designated by MTE. See General Specifications part G of Installation requirements above for further information.
4. Continuous comm raceway from comm hand hole to directly below the meter base will be furnished and installed by the member to the following specifications:
  - A. Conduit to be 1" gray PVC sch 40 or HDPE SDR 13.5, along with any appropriate fitting.
  - B. Conduit will run to 12-18" above final grade below the meter and shall be strapped to wall approximately 6" below the top of the conduit with a minimum of 1/2" stainless steel strap.
  - C. Wall conduit must have appropriate end cap installed with glue.
  - D. Under certain loading and/or density conditions, an alternative size conduit may be used with the written approval of MTE Engineering.
  - E. Comm conduit should be installed in the same ditch as the electrical conduit. The comm conduit shall meet the same depth and bedding requirements as the electrical conduits.
  - F. A polyvinyl, non-rot or mildew proof, pull string with a minimum breaking strength of 200 pounds is to be installed in the raceway.
5. A MTE approved meter base of proper size and type shall be furnished and installed by the member. See General Metering Requirements for additional metering information.

	
<b>UNDERGROUND RESIDENTIAL SERVICE</b> (PAD MOUNT TRANSFORMER)	
DRAWING NUMBER:	REVISED DATE:
ESG-3	OCT. 2, 2023
SCALE: <u>NONE</u>	
SHEET: <u>1</u> OF <u>1</u>	

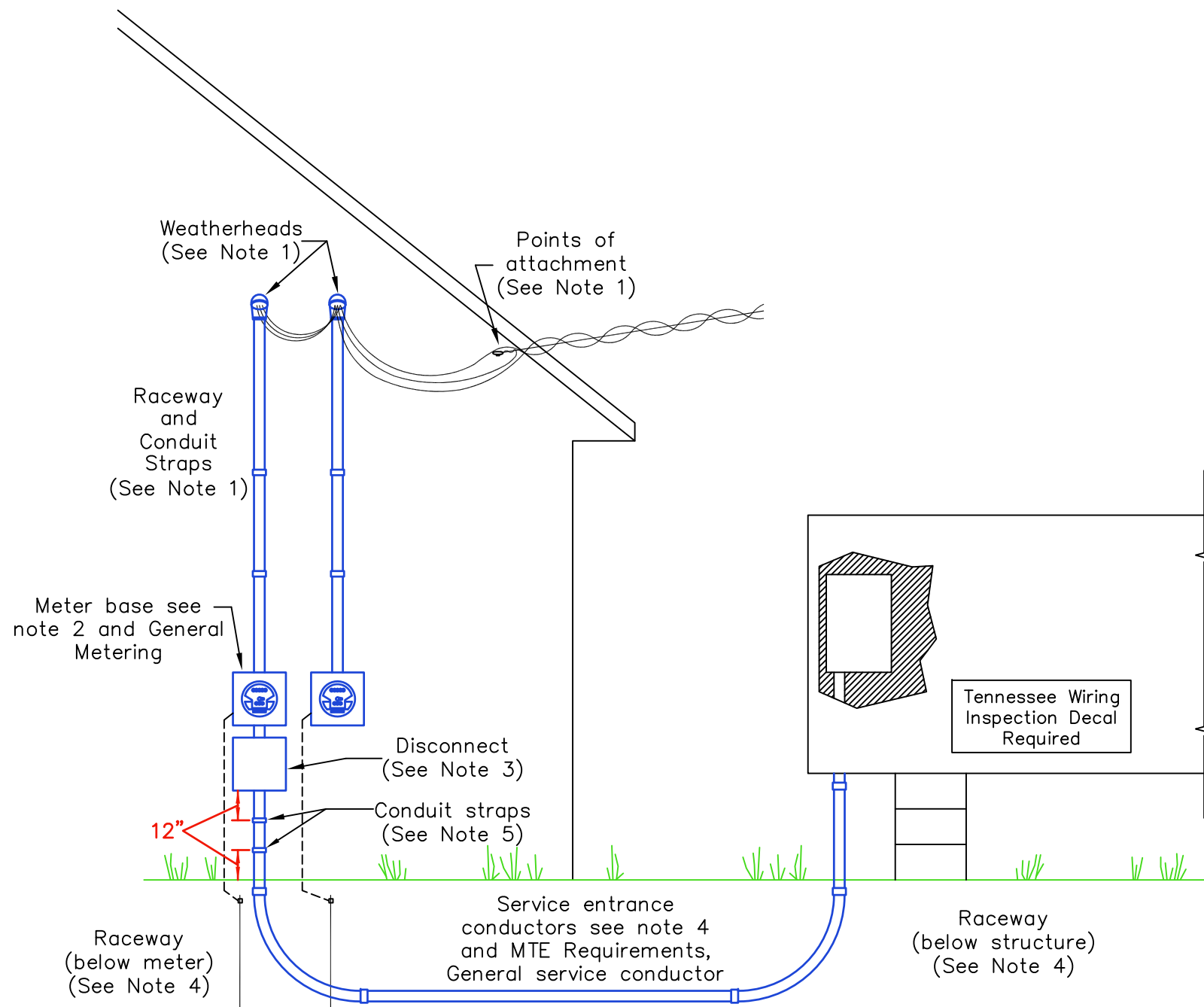

Notes:

An external building can sometimes be served efficiently by installing the new meter beside an existing meter on a house or building. While this usually results in lower construction costs, members are subject to additional charges if existing service drop conductor size or transformer size must be increased.

1. Maximum separation between weatherheads shall be no more than 2 ft. Additional specifications for weatherheads, points of attachment, clearances, service entrance conductors, conduit, etc., are identical to Overhead Residential Service.
2. A MTE approved meter base and hub of proper size and type shall be furnished and installed by the member. See General Metering Requirements for additional metering information.
3. If connecting to a manufactured home a weatherproof, UL listed, multi-circuit disconnect is to be located within 30 feet of the manufactured home. Whether located below meter base on member's pole or on stub, in no case will disconnect be less than 2 feet above grade.
4. For information about conductors, conduit and grounding, refer to National Electrical Code
5. 2 Conduit Straps: Place one conduit strap 12" below disconnect and place second strap 12" above ground.



ADDITIONAL  
METER ON  
HOUSE

DRAWING NUMBER:

ESG-4

REVISED DATE:  
MAY 23, 2013

SCALE: NONE

SHEET: 1 OF 1

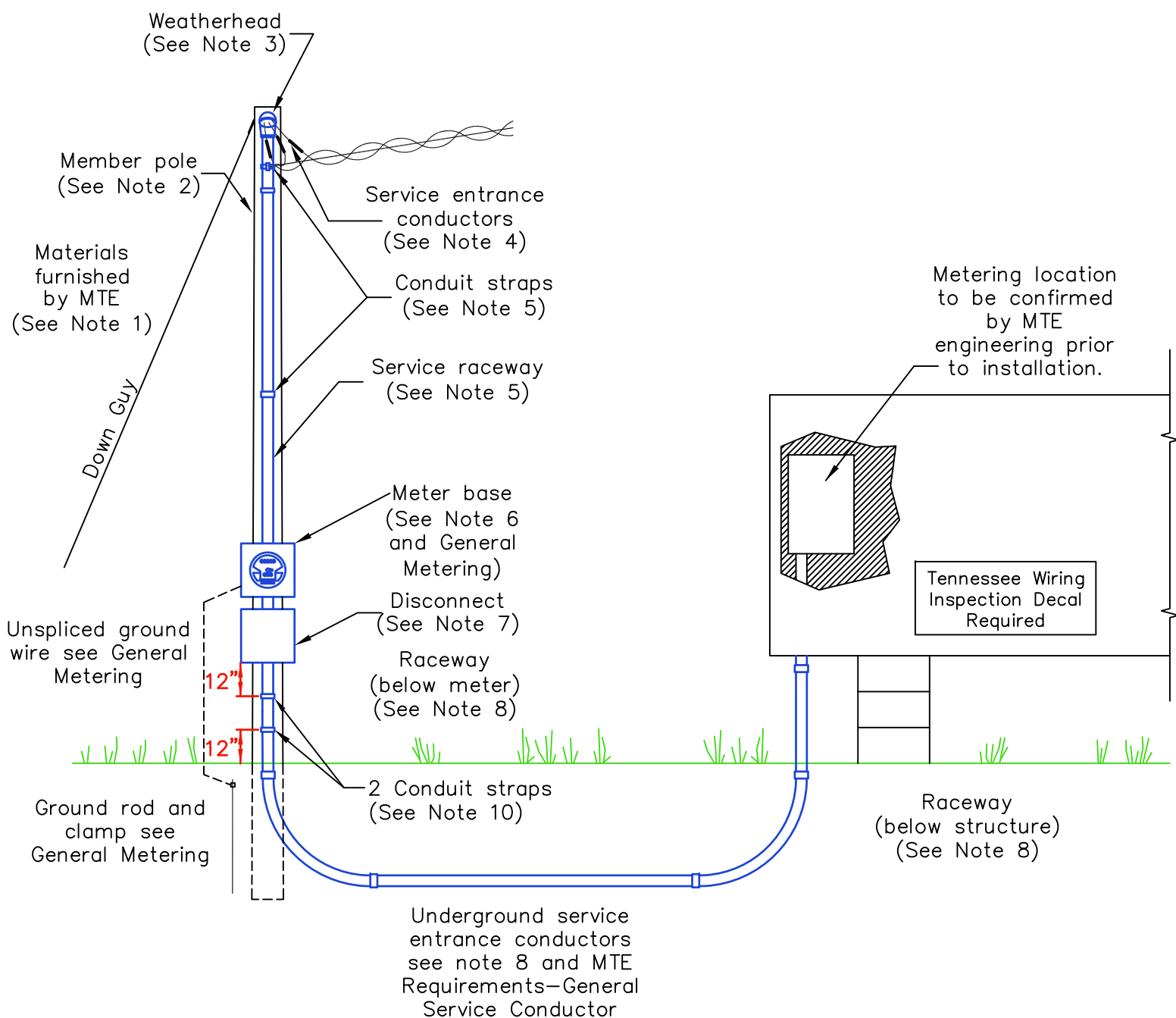

Notes:

1. Member poles allowed for municipal purposes only. (eg. TDOT traffic cameras, city traffic signalization, school crossing signalization, or similar uses as approved by MTE engineering).
2. For residential purposes, the member shall install an underground service to a free standing meter center, either a uni-strut (MTE drawing FSMC-2), a cabinet type (MTE drawing FSMC-3) or post (MTE drawing FSMC-4).
3. Where meter service will be located on Member's pole, MTE will furnish and install:
  - A. service drop conductor from service pole to member's pole
  - B. guy wires and anchors as required (minimum 10 ft. separation between pole and anchor).
4. Location and height of member pole to be determined by a MTE engineering representative. Member's pole will be a treated utility pole set a minimum of 5 feet in the ground.
5. The service drop must be between 6" and 12" from the top of the pole. The weatherhead must be within 12" from the service drop, and it can be above or below the service drop.
6. Service entrance conductor must extend 36" out of the weatherhead.
7. Rigid conduit, IMC, EMT, or SC. 80 electrical PVC with rain-tight couplings and connectors may be used as service entrance conductor raceway. Service entrance raceways will be secured with a minimum of 2 conduit straps, the lower being within 3 ft. of top of meter base.
8. A MTE approved meter base and hub of proper size and type shall be furnished and installed by the member.
9. Whether located below meter base on member's pole or on stub, in no case will disconnect be less than 2 feet above grade. If spacer block in necessary behind meter base or disconnect, use metal brackets.
10. For information about conductors, conduit and grounding, refer to National Electrical Code.
11. See General Metering Requirements for additional metering information.
12. 2 Conduit Straps: Place one conduit strap 12" below disconnect and place second strap 12" above ground.
13. In the case of an existing member pole replacement, if the old member pole is used for non-municipal purposes, the re-build shall incorporate a freestanding meter center or cabinet type base as shown in MTE drawing FSMC-2, FSMC-3 or FSMC-4.



**MEMBER POLE SERVICE  
(FOR MUNICIPAL  
PURPOSES ONLY)**

DRAWING NUMBER:	REVISED DATE:
<b>ESG-5</b>	JULY 1, 2022
	SCALE: <u>NONE</u>
	SHEET: <u>1</u> OF <u>1</u>

Notes:

MTE will provide service to temporaries that have passed state wiring inspection at present site and meet the following wiring and construction standards:

1. Service equipment and meter base securely fastened to a 2 in. metal pipe, 4x4 post, or 2x8 board, and set in the ground at a minimum depth of 2 ft.
2. Temporaries will not be attached to trees or to MTE poles.
3. Each temporary will have a minimum of 4 braces; 2 of which will brace against pull of service drop. Braces will be attached at least 9 ft high on pole and extend at least 6 ft from pole to base.
4. Temporary service will not be located more than 125 ft. from existing MTE service pole. Consult with a MTE engineering representative for specific location, if necessary.
5. Weatherhead must be above point of service drop attachment.
6. The contractor will furnish and install a 5/8" eyebolt, preformed dead end, insulator, and Minimum No. 4 aluminum triplex pigtail.
7. Point of service drop attachment will be of sufficient height to provide a minimum clearance of 12 ft.
8. Service entrance conductors should extend from weatherhead to grade after connecting to pigtail and attaching pre-formed dead end to 5/8" eyebolt.
9. Service entrance raceway may be rigid conduit, EMT, IMC, or schedule 40 electrical PVC with rain-tight couplings and connectors. Service entrance cable with weatherhead may also be used.
10. A weatherproof, UL listed temporary service panel will be located below MTE approved meter base. In no case will the bottom of the panel be less than 2 feet above grade.
11. All receptacles will have ground fault protection for personnel unless otherwise exempted by the NEC.
12. If a temporary service has been left in place for 3 years it must be removed and a permanent service must be installed.
13. See General Metering Requirements for additional metering information.

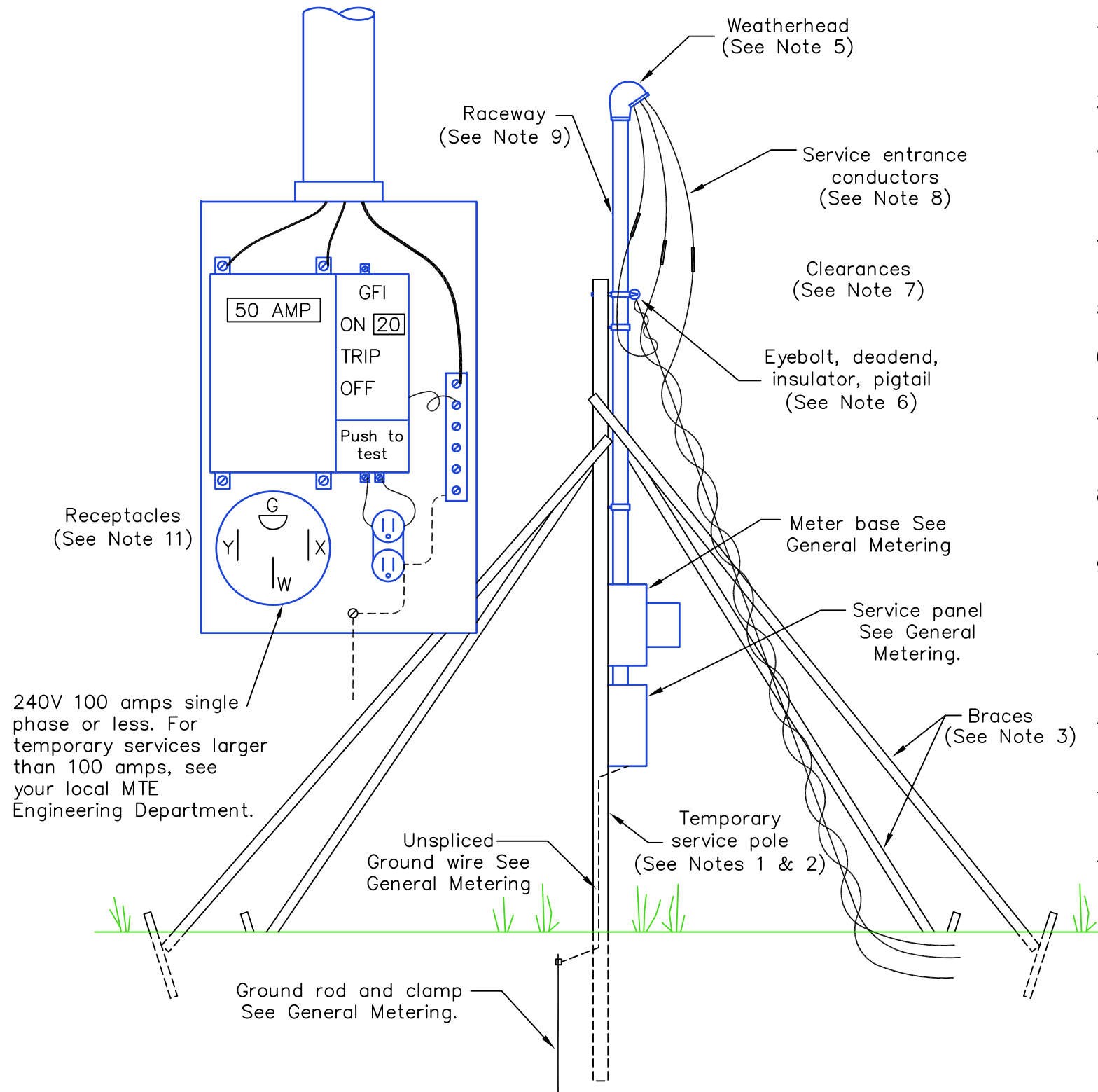

Note: All materials furnished and installed by contractor.



OVERHEAD  
TEMPORARY  
SERVICE

DRAWING NUMBER:

ESG-6

REVISED DATE:

MAY 15, 2013

SCALE: NONE

SHEET: 1 OF 1



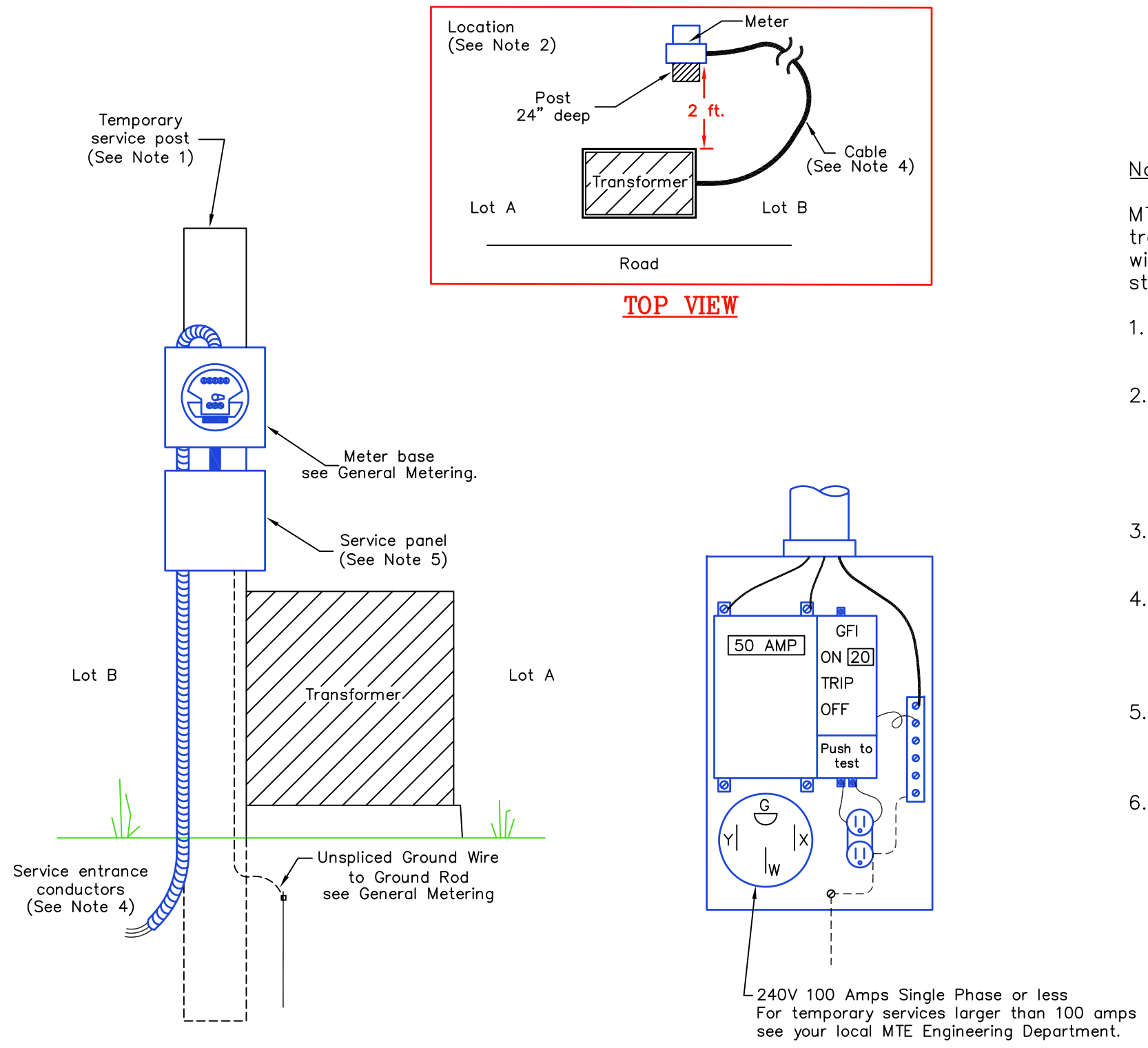

Notes:

MTE will provide service to temporaries located adjacent to pad-mounted transformers or underground secondary boxes. Temporary must pass state wiring inspection at present site and meet the following wiring and construction standards:

1. Service equipment and meter base securely fastened to a 4x4 post set in the ground at a minimum depth of 2 ft.
2. Locate post behind right rear corner of pad-mounted transformer or underground secondary box. Allow 2 ft. clearance between post and transformer or secondary box. If the preferred location can not be obtained, a MTE engineering representative must spot the location for new temporary service as well as additional temporary services.
3. Service entrance raceway of weatherproof flexible conduit will extend from bottom of panel to not less than 1 ft. below grade.
4. Service entrance conductors will extend 10 ft. out of service entrance raceway. Connections in transformer cabinet or underground secondary box will be made by MTE. Access shall be provided to the middle of a transformer pad or the bottom of a secondary box.
5. A weatherproof, U.L. listed, temporary service panel will be located at the MTE approved meter base. In no case will the bottom of the panel be less than 2 ft. above grade.
6. See General Metering Requirements for additional metering information.

Be sure to call  
**Tennessee One Call**  
before driving ground rods  
1-800-351-1111 or 811

	
<p><b>UNDERGROUND TEMPORARY SERVICE</b></p>	
<p>DRAWING NUMBER:</p> <p style="font-size: 2em;"><b>ESG-7</b></p>	<p>REVISED DATE:</p> <p>JULY 1, 2021</p> <p>SCALE: <u>NONE</u></p> <p>SHEET: <u>1</u> OF <u>1</u></p>

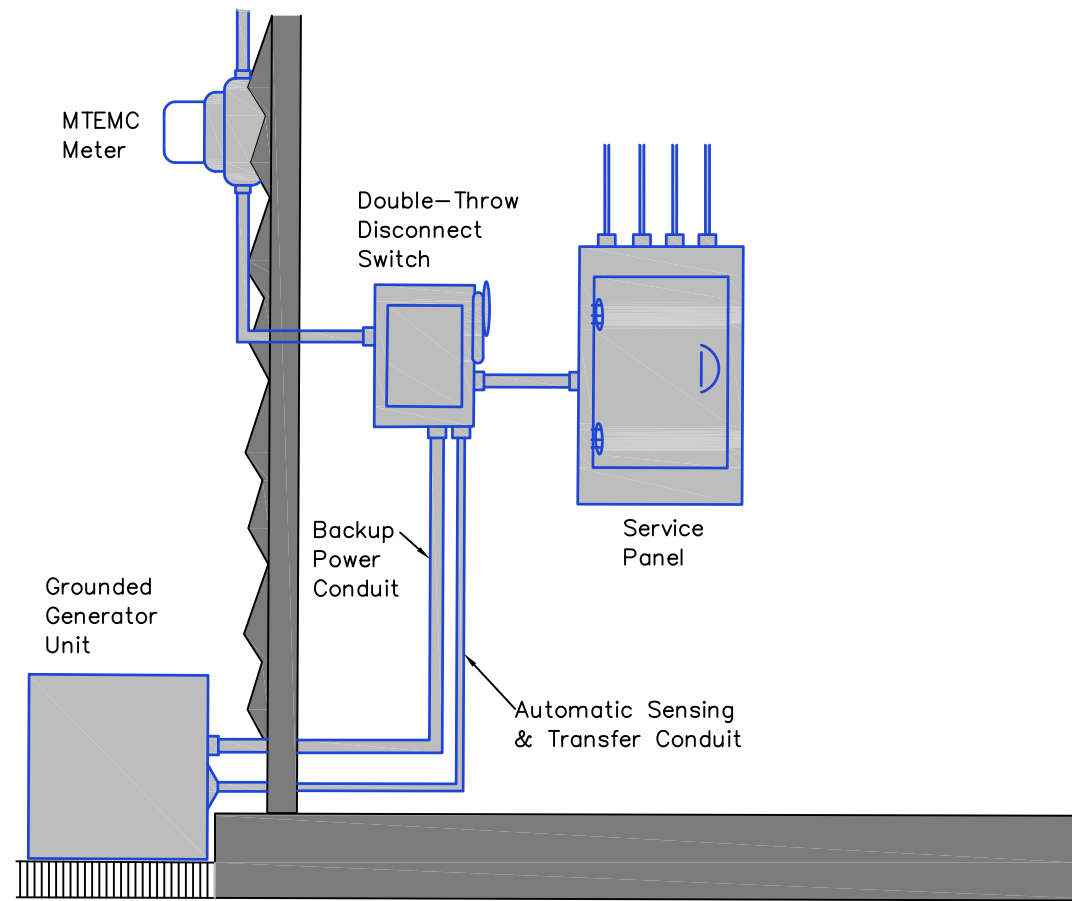

**Notes:**

**Preface**

At Middle Tennessee Electric, the safety of our Members and Employees is of highest importance. In keeping with this philosophy, the following is a guideline for our members who wish to use power generators both at the residential and commercial level.

For Green Power Partners (solar, wind, etc.) contact a MTE engineering representative.

**Definition**

Article 702 of the National Electric Code states that "Optional standby systems are intended to protect private business or property where life safety does not depend on the performance of the system. Optional standby systems are intended to supply on-site generated power to selected loads either automatically or manually."

Any standby generators connected to MTE service locations will be considered "Optional standby systems." All specifications to follow will be regarding said systems.

**Requirements**

It is required that a "double throw switch" be present when a generator is connected to an MTE service point. The purpose of a double throw switch is to isolate an installed generator from the MTE system. A double throw switch will ensure that the generator is not interconnected with MTE distribution lines. In the event of a power outage, the absence of such a switch could endanger MTE employees conducting repairs on the lines. Be aware that during an outage, a generator interconnected with the MTE system can result in serious injury including the death of any MTE employees working to restore power. A double throw switch will insure interconnection does not exist. The distribution panel circuit breaker is not a sufficient method of system isolation. Installed switches must be approved by a state of Tennessee Licensed Electrical Inspector.

**Required Switch Configuration**

The diagrams shown describe how the double throw switch should be configured with your connection.

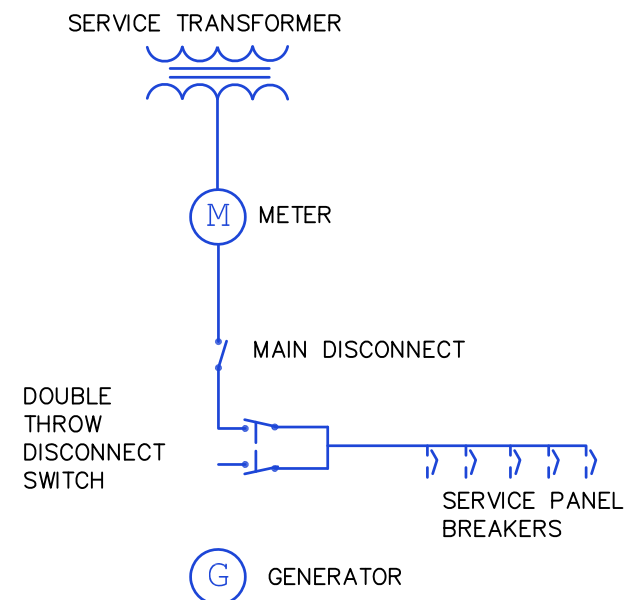

**DOUBLE THROW SWITCH CONFIGURATION OF MTE**

**SERVICE AND STANDBY GENERATOR**

DRAWING NUMBER:	REVISED DATE:
<b>ESG-9</b>	AUG. 26, 2011
SCALE:	<u>NONE</u>
SHEET:	<u>1</u> OF <u>1</u>

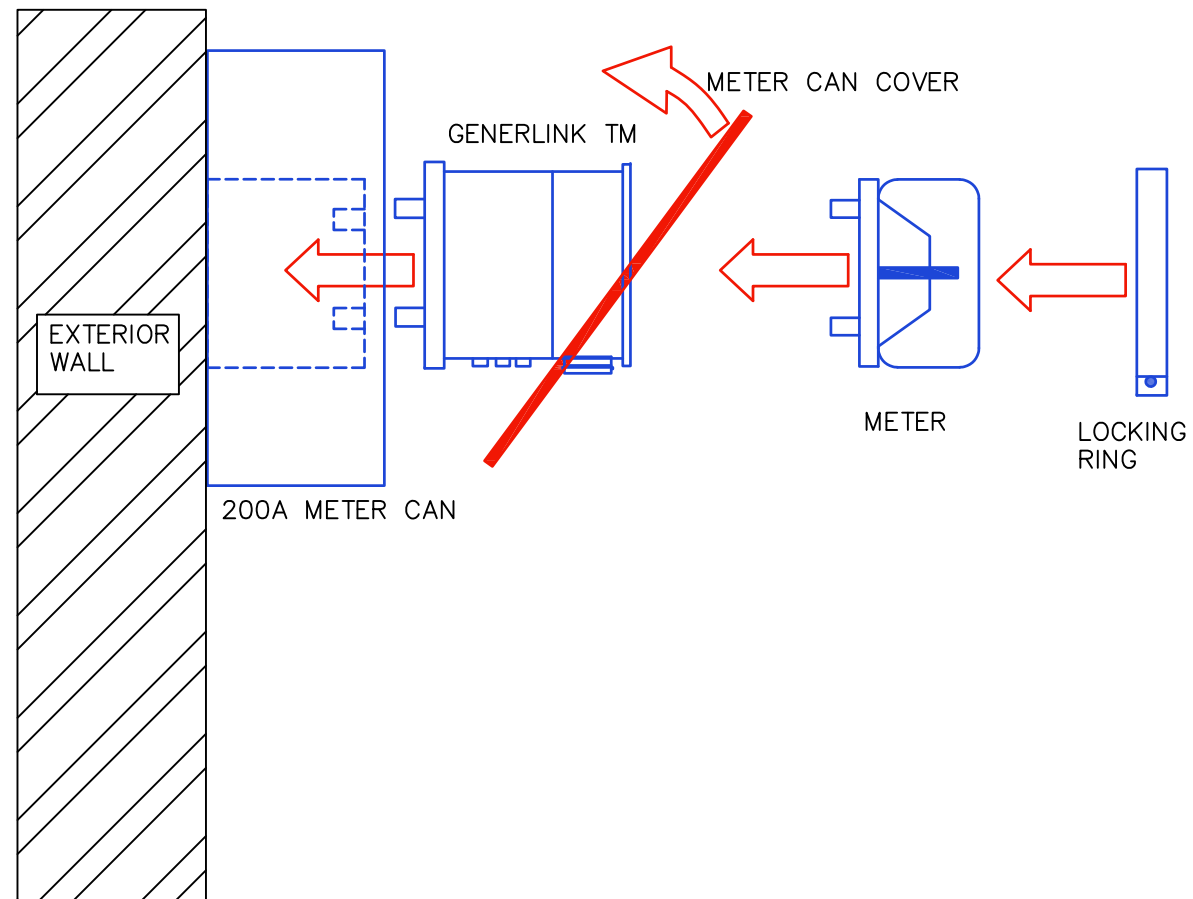

Notes:

Preface

At Middle Tennessee Electric, the safety of our Members and Employees is of highest importance. In keeping with this philosophy, the following is a guideline for our members who wish to use Generlink brand meter collars for quick connection/disconnection for portable generators both at the residential and commercial level.

For Green Power Partners (solar, wind, etc.) contact a MTE engineering representative.

Definition:

Article 702 of the National Electric Code states that "Optional standby systems are intended to protect private business or property where life safety does not depend on the performance of the system. Optional standby systems are intended to supply on-site generated power to selected loads either automatically or manually."

Any standby generators connected to MTE service locations will be considered "Optional standby systems." All specifications to follow will be regarding said systems.

Requirements:

1. Main distribution panel must be 200 amps or less. Panels greater than 200 amps will be required to install the normal transfer switch arrangement as shown in drawing ESG-9.
2. Member must purchase the Generlink device.
3. MTE will install the Generlink device.
4. Only the Generlink MA23/24-N/S device will be allowed.

The diagrams shown describe how the Generlink device should be configured with your connection.

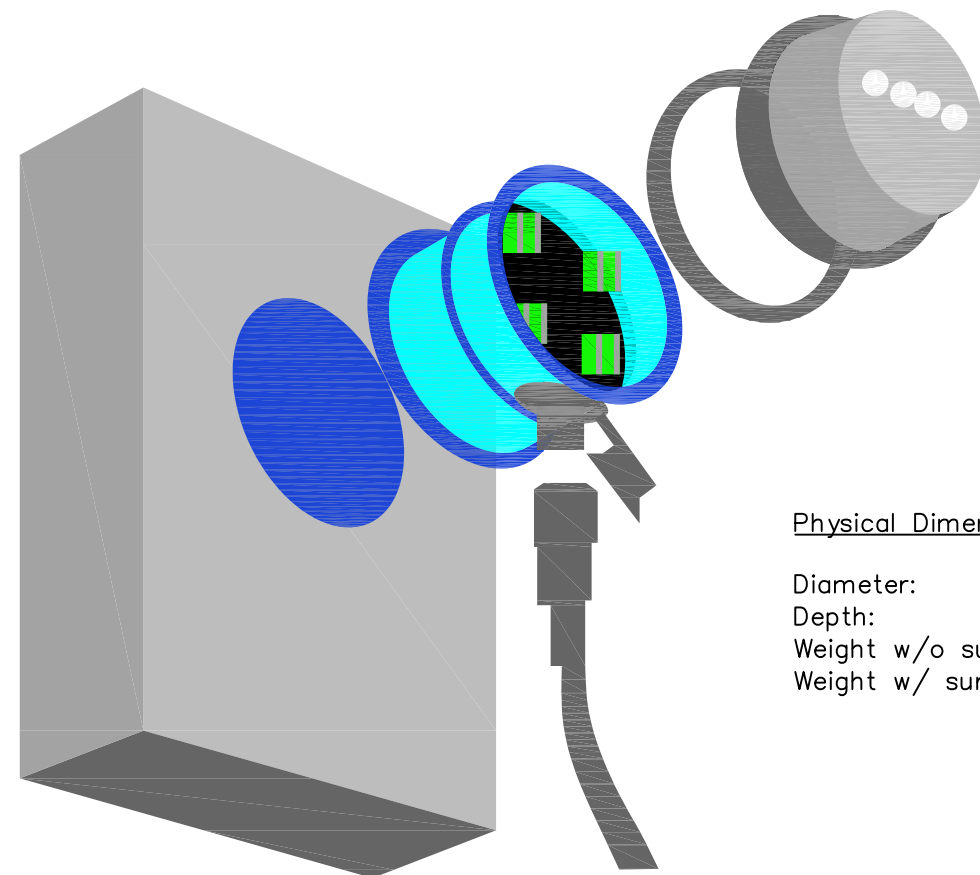

Physical Dimensions:

Diameter: 6½"  
 Depth: 5¼"  
 Weight w/o surge: 5½ lbs  
 Weight w/ surge: 5¾ lbs



**GENERLINK  
METER COLLAR**

**PORTABLE GENERATOR CONNECTOR**

DRAWING NUMBER:	REVISED DATE:
<b>ESG-10</b>	JAN. 31, 2012
	SCALE: <u>NONE</u>
	SHEET: <u>1</u> OF <u>1</u>

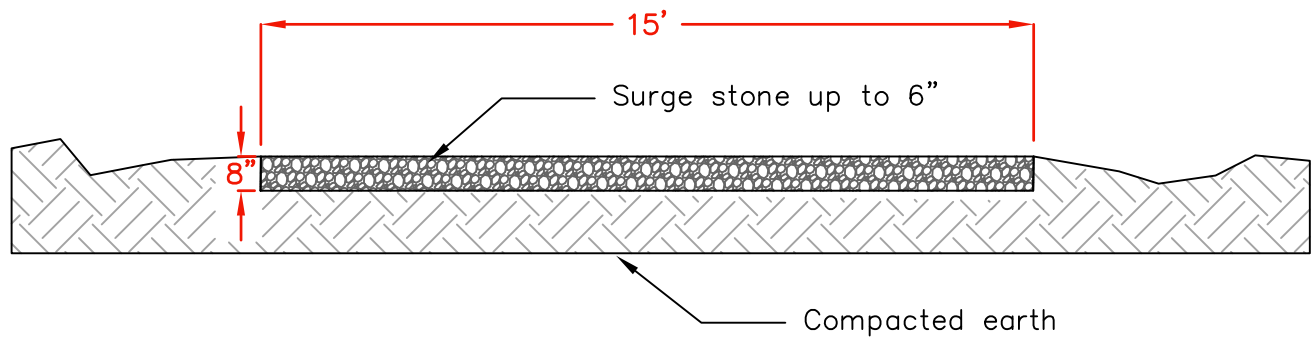

Notes

1. Use surge stone up to 6”.
2. Gravel depth shall be a minimum 8”.
3. Curves shall have a 25’ minimum radius.
4. Drainage tiles or culverts shall be added as necessary to protect the integrity of the all-weather road.
5. An all-weather road may be required when facilities are installed away from traffic accessible surfaces. Consult with MTE Engineering to determine if an all-weather road will be required.
6. Driveway cuts shall be made in curbs and/or sidewalks when present.



ALL WEATHER ROAD

DRAWING NUMBER:

ESG-11

REVISED DATE:

DEC. 27, 2018

SCALE: NONE

SHEET: 1 OF 1

Notes:

\*Be sure to call Tennessee One Call before digging or opening ditches: 1-800-351-1111 or 811  
 \*Underground Inspection 1-877-886-8362

1. MTE will furnish and install the following materials at the service pole:
  - A. Conduit up the service pole, to include all related hardware.
  - B. Service conductor from transformer to meter pedestal.
2. Member will open ditch from service pole or junction box to meter location with the following specifications:
  - A. Where ditch length will exceed 150 ft. see MTE engineering representative prior to opening ditch
  - B. Hand-dig ditch when within 5 ft. of transformer.
  - C. Depth sufficient to bed conduit with service conductors 24 in. below final grade.
  - D. Where impractical to obtain 24 in. depth, see a MTE engineering representative.
  - E. Member will backfill ditch after inspection by MTE (call 877-886-8362 or visit [www.MTE.com](http://www.MTE.com) to fill out an online request)
3. Continuous raceway from transformer to meter base will be furnished and installed by member to the following specifications:
  - A. Conduit size is to be 3 inch as specified below with appropriate fittings and/or bushings as required. For all conduit connections use long, (6" minimum) integral belled end conduit.
  - B. Raceway below grade/between elbows is to be schedule 40 electrical PVC or schedule 80 electrical PVC conduit.
  - C. Elbows are to be schedule 80 electrical PVC with a sweeping radius of 24 inches.
  - D. Conduit extending from meter base to one foot below grade is to be schedule 80 electrical PVC
  - E. Where junction box (not shown) is present at service pole, see a MTE engineering representative for specifications.
  - F. A polyvinyl, non rot or mildew proof, pull string with a minimum breaking strength of 200 pounds is to be installed inside the raceway.
  - G. Under certain loading and/or density conditions, an alternate sized conduit may be used with the approval of MTE district office engineering representative.

4. Service conductors see "General Service Conductor Requirements"
5. The bottom of a weatherproof, UL listed, multi-circuit disconnect shall be located no less than 2 ft. above grade.
6. For information about conductors, conduit and grounding, refer to National Electric Code.
7. See General Metering Requirements for additional metering information.
8. The location of free standing meter centers (FSMC) shall be at the sole discretion of MTE engineering with the following constraints:
  - A. When a FSMC is served from a pole/overhead feed, the FSMC should be a minimum of 10' from the utility pole.
  - B. When a FSMC is placed in a residential development, the power source should originate from a pull box, not a pole.
9. Install 1" comm. conduit as indicated. Strap conduit to first cross member, install appropriate cap on conduit.

**NOTE: Verify disconnect location by referring to the General Metering Requirements**

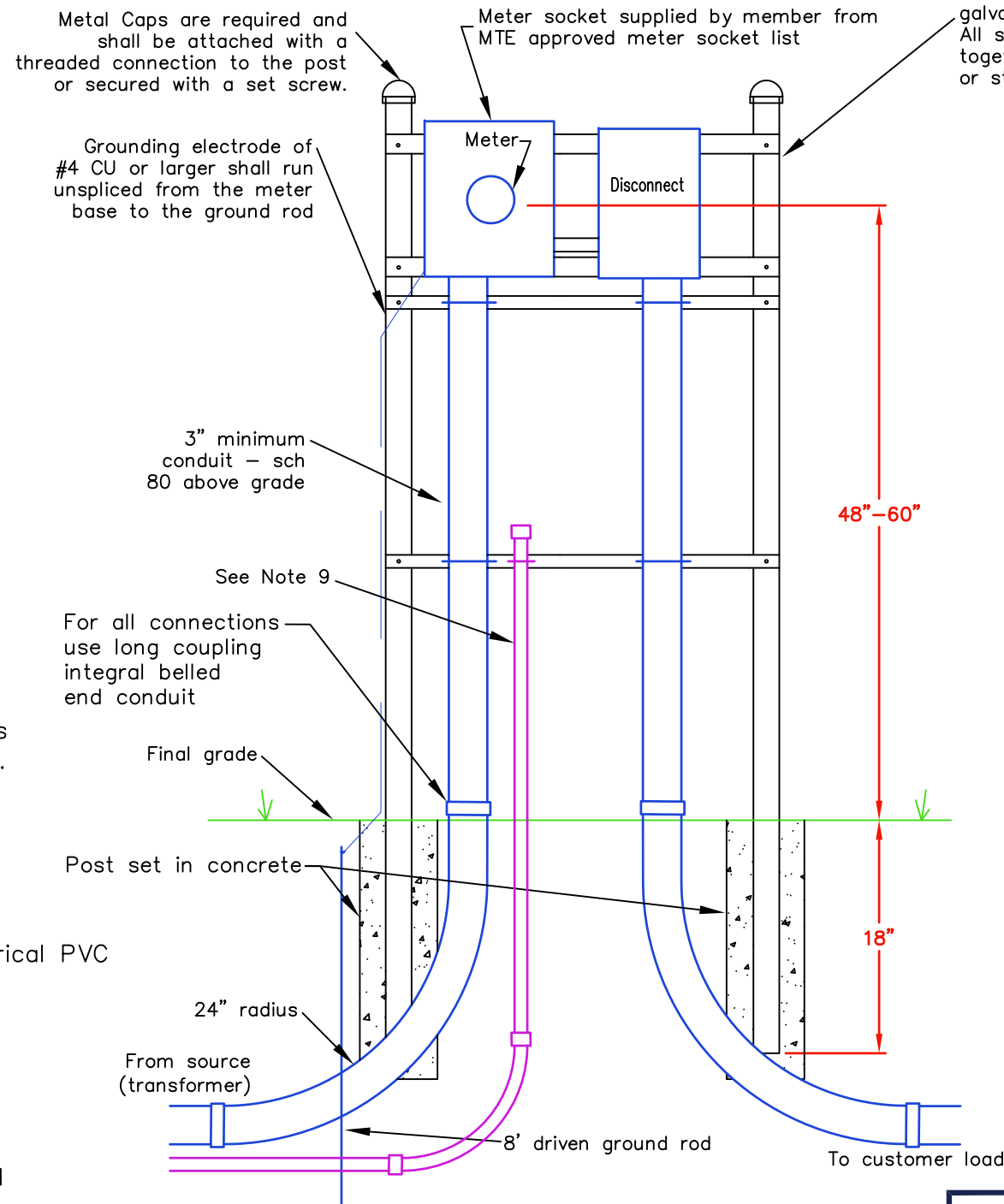

**PLAN VIEW**

2" galvanized rigid metal conduit with 12 gauge minimum thickness galvanized unistrut supports. All supports are to be bolted together using galvanized or stainless steel hardware.

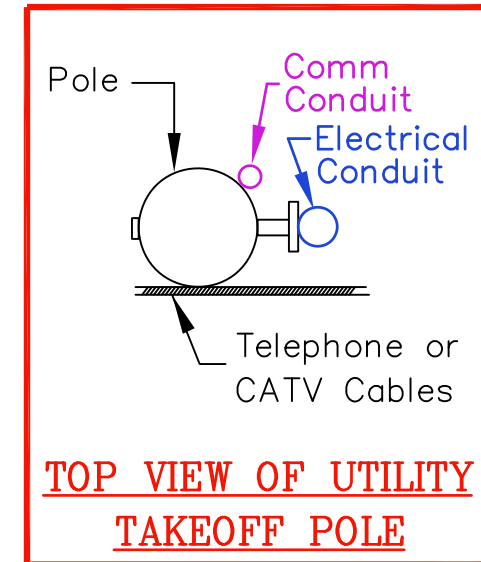
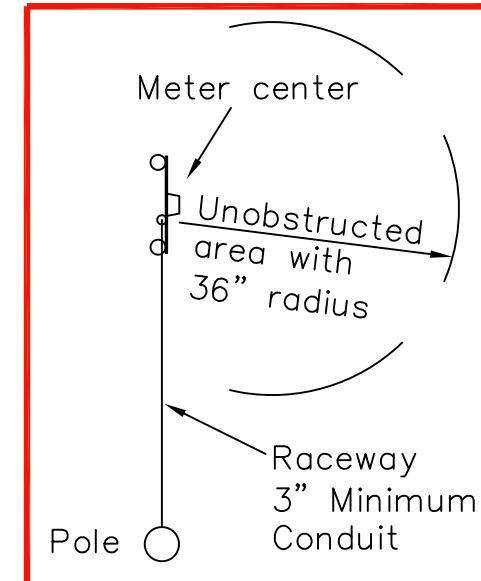

**FREE STANDING METER CENTER**

<b>DRAWING NUMBER:</b>	<b>REVISED DATE:</b>
<b>FSMC-2</b>	APRIL 1, 2024
	SCALE: <u>NONE</u>
	SHEET: <u>1</u> OF <u>1</u>



Notes:

\*Be sure to call Tennessee One Call before digging or opening ditches: 1-800-351-1111 or 811  
 \*Underground Inspection 1-877-886-8362

1. MTE will furnish and install the following materials at the service pole:
  - A. Conduit up the service pole, to include all related hardware.
  - B. Service conductor from transformer to meter pedestal.
2. Member will open ditch from service pole or junction box to meter pedestal with the following specifications:
  - A. Where ditch length will exceed 150 ft. see MTE engineering representative prior to opening ditch
  - B. Hand-dig ditch when within 5 ft. of transformer.
  - C. Depth sufficient to bed conduit with service conductors 24 in. below final grade.
  - D. Where impractical to obtain 24 in. depth, see a MTE engineering representative.
  - E. Member will backfill ditch after inspection by MTE (call 877-886-8362 or visit www.MTE.com to fill out an online request)
3. Continuous raceway from transformer to meter pedestal will be furnished and installed by member to the following specifications:
  - A. Conduit size is to be 3 inch as specified below with appropriate fittings and/or bushings as required. For all conduit connections use long, (6" minimum) integral belled end conduit.
  - B. Raceway below grade/between elbows is to be schedule 40 electrical PVC or schedule 80 electrical PVC conduit.
  - C. Elbows are to be either schedule 80 electrical PVC with a sweeping radius of 24 inches.
  - D. Raceway above grade to one foot below grade is to be schedule 80 electrical PVC.
  - E. Where junction box (not shown) is present at service pole, see a MTE engineering representative for specifications.
  - F. A polyvinyl, non rot or mildew proof, pull string with a minimum breaking strength of 200 pounds is to be installed inside the raceway.
  - G. Under certain loading and/or density conditions, an alternate sized conduit may be used with the approval of MTE district office engineering representative.
4. Concrete base to be 19" H minimum, extend a minimum of 6" beyond the enclosure, and 4" - 6" above final grade.
5. Foundation shall be fiber reinforced concrete. Edge shall be a 1" chamfer.
6. Service conductors see "General Service Conductor Requirements"
7. For information about conductors, conduit and grounding, refer to National Electric Code.
8. See General Metering Requirements for additional metering information.
9. The location of free standing meter centers (FSMC) shall be at the sole discretion of MTE engineering with the following constraints:
  - A. When a FSMC is served from a pole/overhead feed, the FSMC should be a minimum of 10' from the utility pole.
  - B. When a FSMC is placed in a residential development, the power source should originate from a pull box, not a pole.
10. Install 1" comm. conduit against foundation of meter pedestal flush with the final grade and appropriate cap installed on the conduit.

**NOTE: Verify disconnect requirements by referring to General Metering Requirements**

**NOTE: 3' radius unobstructed area required around meter pedestal**

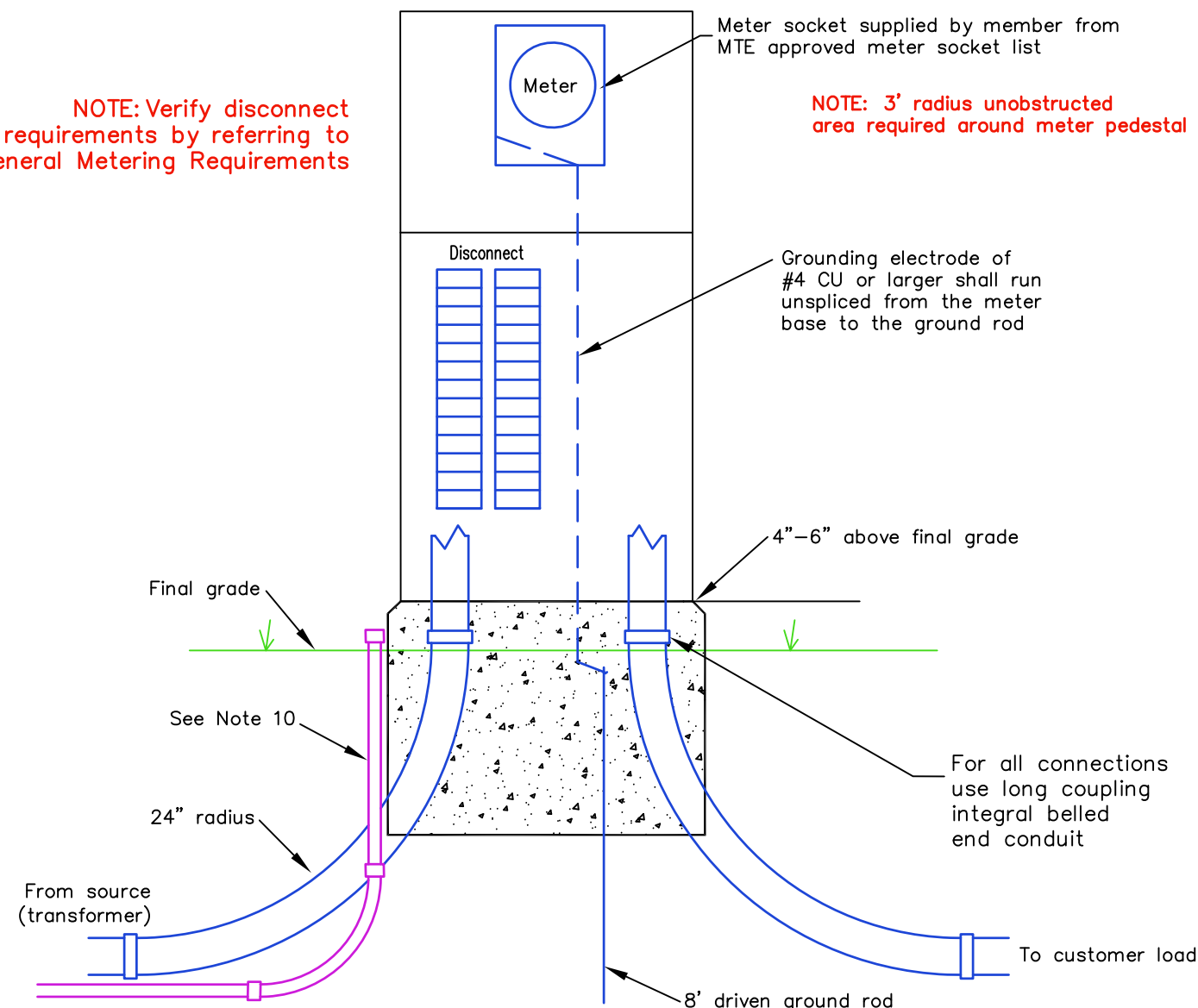

**PLAN VIEW**

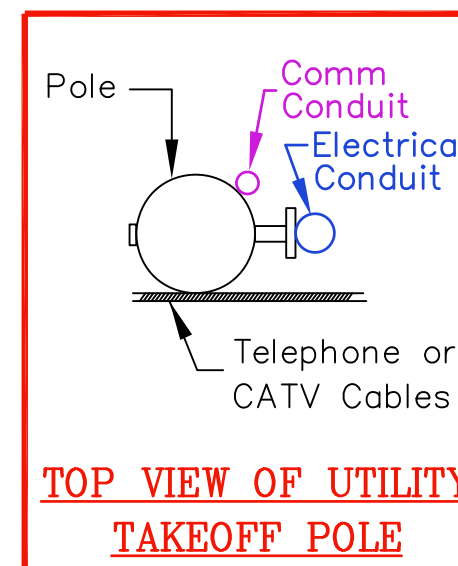

**TOP VIEW OF UTILITY TAKEOFF POLE**

	
<b>METER PEDESTAL</b>	
DRAWING NUMBER: <b>FSMC-3</b>	REVISED DATE: APRIL 1, 2024
SCALE: <u>NONE</u>	
SHEET: <u>1</u> OF <u>1</u>	

**Notes:**

\*Be sure to call Tennessee One Call before digging or opening ditches: 1-800-351-1111 or 811  
 \* Underground Inspection 1-877-886-8362

1. MTE will furnish and install the following materials at the service pole:
  - A. Conduit up the service pole, to include all related hardware.
  - B. Service conductor from the transformer to the meter pedestal.
2. Member will open ditch from service pole or junction box to meter location with the following specifications:
  - A. Where ditch length will exceed 150 ft. see MTE engineering representative prior to opening ditch
  - B. Hand-dig ditch when within 5 ft. of transformer.
  - C. Depth sufficient to bed conduit with service conductors 24 in. below final grade.
  - D. Where impractical to obtain 24 in. depth, see a MTE engineering representative.
  - E. Member will backfill ditch after inspection by MTE (call 877-886-8362 or visit www.MTE.com to fill out an online request)
3. Continuous raceway from transformer to meter base will be furnished and installed by member to the following specifications:
  - A. Conduit size is to be 3 inch as specified below with appropriate fittings and/or bushings as required. For all conduit connections use long, (6" minimum) integral belled end conduit.
  - B. Raceway below grade/between elbows is to be schedule 40 electrical PVC or schedule 80 electrical PVC conduit.
  - C. Elbows are to be schedule 80 electrical PVC with a sweeping radius of 24 inches.
  - D. Conduit extending from meter base to one foot below grade is to be schedule 80 electrical PVC.
  - E. Where junction box (not shown) is present at service pole, see a MTE engineering representative for specifications.
  - F. A polyvinyl, non rot or mildew proof, pull string with a minimum breaking strength of 200 pounds is to be installed inside the raceway.
  - G. Under certain loading and/or density conditions, an alternate sized conduit may be used with the approval of MTE district office engineering representative.
4. Service conductors see "General Service Conductor Requirements"
5. The bottom of a weatherproof, UL listed, multi-circuit disconnect shall be located no less than 2 ft. above grade.
6. For information about conductors, conduit and grounding, refer to National Electric Code.
7. See General Metering Requirements for additional metering information.
8. The location of free standing meter centers (FSMC) shall be at the sole discretion of MTE engineering with the following constraints:
  - A. When a FSMC is served from a pole/overhead feed, the FSMC should be a minimum of 10' from the utility pole.
  - B. When a FSMC is placed in a residential development, the power source should originate from a pull box, not a pole.
9. Install 1" comm. conduit on either side not shared with service conductor conduit. Strap conduit to post, and install appropriate cap on conduit.

**NOTE: Verify disconnect location by referring to the General Metering Requirements**

Meter socket supplied by member from MTE approved meter socket list

BestPLUS G-Grade Synthetic Landscape Timber, Black or Brown, 6" x 6" x 8'  
 (Site One #060608-color)  
 or Priefert 8' octagon metal fence post with cap. (Co-op #OTP96PK20)

Optional metal C-channel to secure socket and disconnect to post.

Grounding electrode of #4 CU or larger shall run unspliced from the meter base to the ground rod

3" minimum conduit -sch 80 above grade

Conduit Straps

Communication conduit (see note 9)

For all connections use long coupling integral belled end conduit

30" MIN. SET IN CONCRETE

From source (transformer)

8' driven ground rod

Meter

12"

48"-60"

12"

Final grade

24" radius

To customer load

**SIDE VIEW**

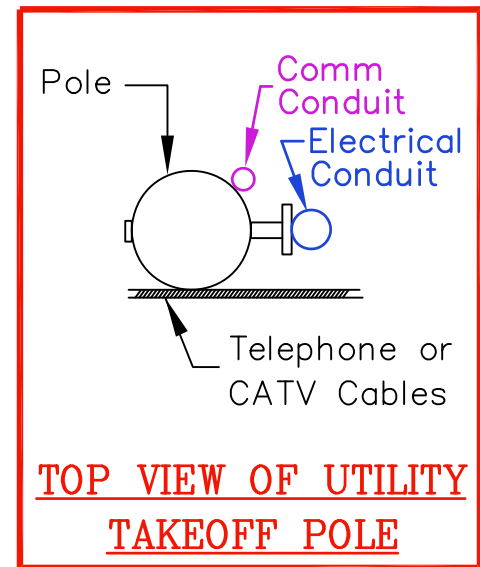
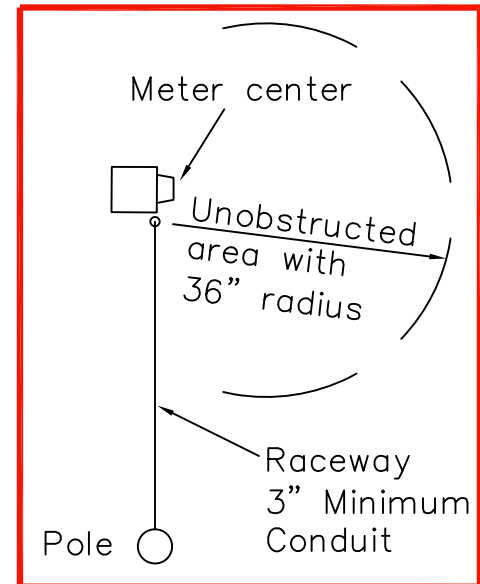

**FREE STANDING METER CENTER**

DRAWING NUMBER:

**FSMC-4**

REVISED DATE:

APRIL 1, 2024

SCALE: NONE

SHEET: 1 OF 1

FOR RETIREMENT ONLY - NOT FOR NEW CONSTRUCTION

FOR RETIREMENT ONLY - NOT FOR NEW CONSTRUCTION

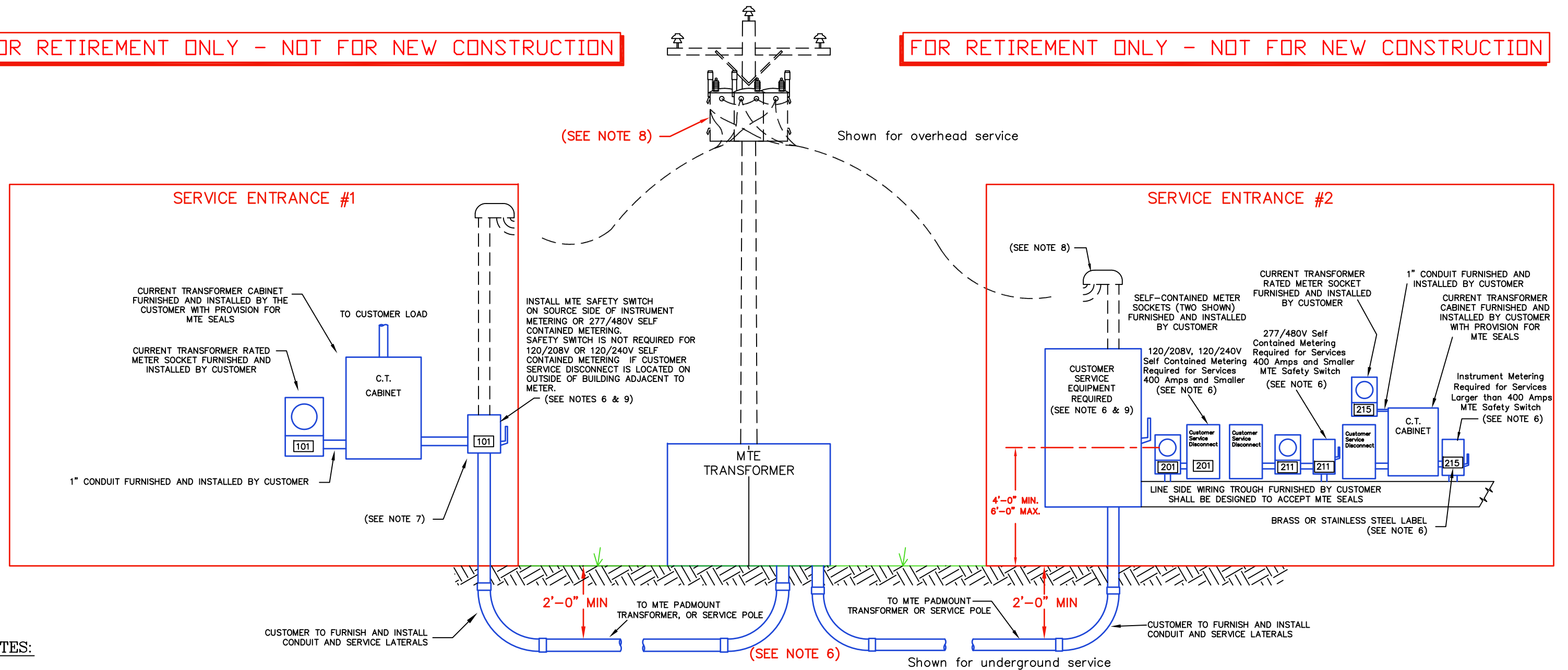

**NOTES:**

1. MTE TO MAKE ALL METERING CONTROL CABLE CONNECTIONS IN METER SOCKET AND C.T. CABINET. CUSTOMER TO MAKE ALL CONNECTIONS IN WIRE TROUGH AND SELF-CONTAINED METER SOCKETS.
2. CONDUCTORS CARRYING METERED AND UN-METERED ENERGY SHALL NOT BE ALLOWED IN SAME WIRING TROUGH OR CONDUIT.
3. ALL WIRING, EQUIPMENT RATINGS, NUMBER OF SERVICES, ETC. SHALL BE IN COMPLIANCE WITH THE NATIONAL ELECTRIC CODE.
4. C.T.'S FURNISHED BY MTE AND INSTALLED BY CUSTOMER IN THE PRESENCE OF MTE PERSONNEL.
5. FOR SINGLE PHASE LOADS FROM A THREE PHASE TRANSFORMER, USE A 5 TERMINAL NETWORK METER SOCKET.
6. REFER TO GENERAL METERING REQUIRMENTS FOR ADDITIONAL METERING INFORMATION.
7. GROUND CUSTOMER SERVICE EQUIPMENT IF PRESENT.
8. FOR OVERHEAD SERVICES, CUSTOMER SHALL FURNISH AND INSTALL CONDUIT AND SERVICE LATERALS. INSTALLATIONS TO BE INSPECTED BY STATE ELECTRICAL INSPECTOR.
9. FOR SERVICE ISOLATION, MAIN DISCONNECT REQUIRED FOR:
  - MULTIPLE TROUGHS FED FROM THE SAME TRANSFORMER
  - MORE THAN SIX METERS ON A SINGLE TROUGH
  - MULTIPLE GANGED METER BASES
  - MULTIPLE BUILDING FEEDS FROM THE SAME TRANSFORMER
10. THIS DRAWING'S SCOPE IS MULTIPLE SERVICE ENTRANCES FROM THE SAME TRANSFORMER. FOR ONE SERVICE ENTRANCE, SEE DRAWING COM-8.

	
<p><b>NON RESIDENTIAL METERING WITH MULTIPLE CUSTOMERS AND SERVICE LATERALS FROM A SINGLE TRANSFORMER</b></p>	
<p>DRAWING NUMBER:</p> <h1 style="margin: 0;">COM-6</h1>	<p>REVISED DATE:</p> <p style="margin: 0;">AUG. 30, 2016</p> <p>SCALE: <u>NONE</u></p> <p>SHEET: <u>1</u> OF <u>1</u></p>



**METER TROUGHS AND TERMINATION ENCLOSURES**

Effective immediately, MTEMC shall not connect any new troughs. Troughs shall be replaced with a termination enclosure (provided by the member) for any new service. Secondary termination enclosures may be required for multiple service entrance applications. Such applications shall be approved by MTEMC Engineering **prior** to installation.

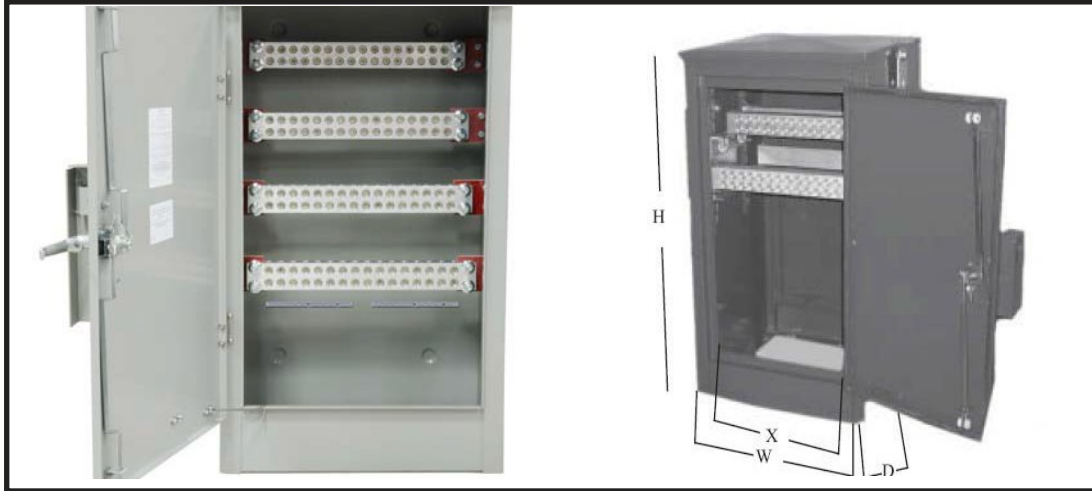

The termination enclosure provided shall be aluminum construction with a powder-coat paint finish. In addition, the enclosure shall be UL listed, pad-lockable, properly rated for the application, and contain penta-head bolt locking mechanism. **Wire shall be sized to the maximum based on lug size in the tap box. Conductor shall not exceed 750 kcmil. All conductor from the transformer to the tap box shall be COPPER. The conduit requirements are listed below from the transformer to the tap box.** MTEMC shall lock and seal each cabinet when service is energized. All conductors shall be routed behind the termination cabinet buss work. Each individual service in the termination enclosure shall be clearly marked, using printed self-laminating labels, by unit number, apartment number, suite number, and/or space number on the service cable. Labels shall be visible from the front. Termination enclosures shall remain the property of the member.

For service isolation, a meter disconnect shall be required for:

- Multiple termination enclosures fed from the same transformer.
- More than 6 services fed from an enclosure or grouped enclosures.
- Multiple ganged meter bases
- Multiple service feeds from the same transformer

**Acceptable Part Numbers**

(Others may be submitted to Support EE for approval provided they meet the criteria above)

*Must order with penta-head bolt	Max Wire Size	Number of Lugs	Number of conduits	W	D	H	Maximum UL Rating
Milbank				Dimensions in inches			CU Amps
UAP-6094-O*	500 kcmil	16	8-4 inch	25 5/8	16	43	3000
UAP-6095-O*	500 kcmil	22	10-4 inch	32 3/8	16	43	4000
UAP-6096-O*	750 kcmil	14	7-4 inch	25 15/16	16	51	3300
CMC/ESP							
LWTE21-500*	500 kcmil	21	8-4 inch	32	16	51	3800
LWTE14-750*	750 kcmil	14	7-4- inch	32	16	51	3325
LWTE14-1000*	750 kcmil	14	9-6 inch	32	16	51	3815
LPTE20-1000*	750 kcmil	20	9-6 inch	36	30	44	5000

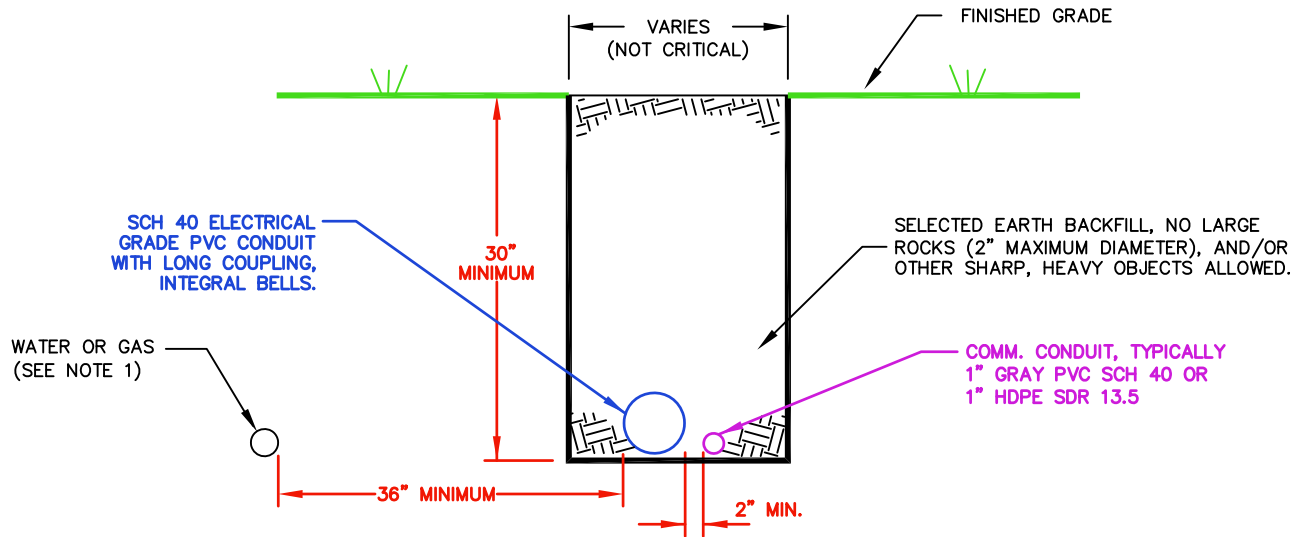

**Notes:**

1. Conduits run horizontal to water or gas lines must have a minimum 36" horizontal separation.
2. Telephone or cable utility minimum separation from MTE ducts shall be either:
  - a.) 36" parallel
  - b.) 12" vertical
3. All foreign utility perpendicular crossings must have 12" minimum separation from MTE ducts.
4. PVC Conduit shall be gray schedule 40 with long integral bells. The size and number as specified by MTE and indicated on the plans. Long couplings defined as 6" or longer for 3" conduit shall be used as necessary.
5. Comm conduit to be gray schedule 40 PVC or HDPE SDR 13.5 orange with red stripe. Use only approved couplings from Appendix B of MTE UIG.
6. No sharp bends will be allowed. Horizontal bends must be greater than 6' radius. Contractor should plan runs to building sites such that no sharp bends will be necessary to serve the building.
7. Install Jetline pull string with minimum 200 lb tensile strength in each conduit.
8. If above not practical, then options shown on secondary ditch detail 2S may be used.
9. Developer/owner is responsible for providing MTE a clean and obstruction free conduit system.
10. Multiple family units require the minimum conduit requirements:
  - Townhomes:
    - Up to 5 units - one (1) conduit to the gang base.
    - 6 units or larger - two (2) conduits to the gang base.
  - Apartments:
    - 1 to 11 units - one (1) 3" conduit to each gang base.
    - 12 to 36 units - two (2) 3" conduits to each gang base.
  - Two (2) 3" conduits for all road crossings
11. Uppermost electrical conduit shall have no less than 24" of cover to surface / ground line.

	
<p><b>SECONDARY DITCH DETAIL</b></p>	
<p><b>DRAWING NUMBER:</b></p> <p style="font-size: 2em; text-align: center;">1S</p>	<p><b>REVISED DATE:</b> APRIL 1, 2024</p> <hr/> <p><b>SCALE:</b> <u>  NONE  </u></p> <hr/> <p><b>SHEET:</b> <u>  1  </u> OF <u>  1  </u></p>

**THE FOLLOWING OPTION IS ALLOWED AT DISCRETION OF MTE ENGINEERING  
WHERE ROCK WILL NOT ALLOW DRAWING 1S TO WORK.**

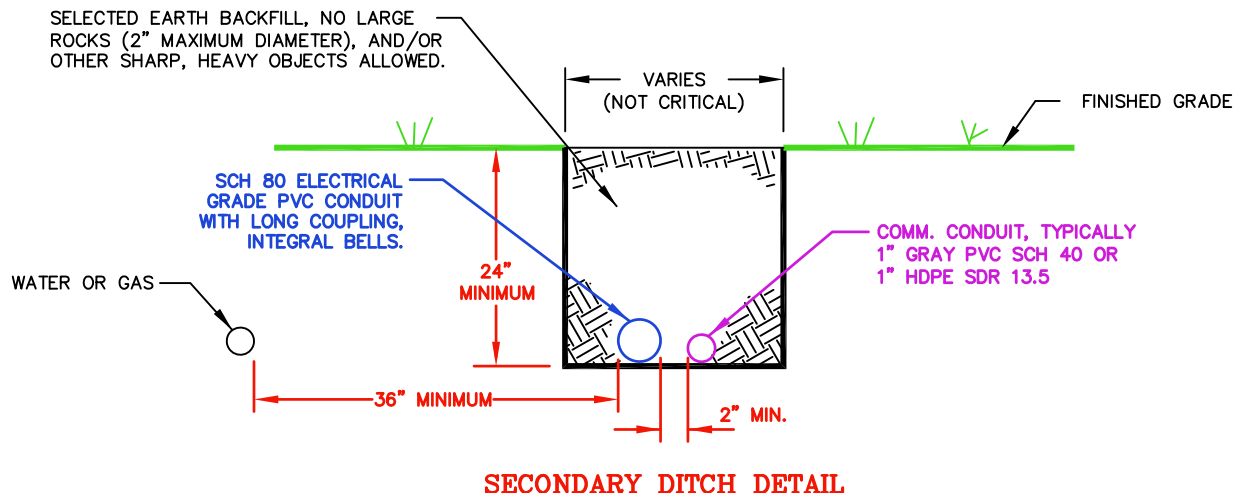

**NOTES:**

1. Use secondary ditch detail 1S where practical; the above option only if detail 1S is not practical.
2. Conduits run horizontal to water or gas lines must have a minimum 36" horizontal separation.
3. Telephone or cable utility minimum separation from MTE ducts shall be either:
  - a.) 36" parallel
  - b.) 12" vertical
4. All foreign utility perpendicular crossings must have 12" minimum separation from MTE ducts.
5. PVC Conduit shall be gray schedule 40 with long integral bells. The size and number as specified by MTE and indicated on the plans. Long couplings defined as 6" or longer for 3" conduit shall be used as necessary.
6. Comm conduit to be gray schedule 40 PVC or HDPE SDR 13.5 orange with red stripe. Use only approved couplings from Appendix B of MTE UIG.
7. No sharp bends will be allowed. Horizontal bends must be greater than 6' radius. Contractor should plan runs to building sites such that no sharp bends will be necessary to serve the building.
8. Install Jetline pull string with minimum 200 lb tensile strength in each conduit.
9. Long couplings defined as 6" or longer for 3" conduit shall be used as necessary.
10. Developer/owner is responsible for providing MTE a clean and obstruction free conduit system.
11. Multiple family units require the minimum conduit requirements:
  - Townhomes:
    - Up to 5 units – one (1) conduit to the gang base.
    - 6 units or larger – two (2) conduits to the gang base.
  - Apartments:
    - 1 to 11 units – one (1) 3" conduit to each gang base.
    - 12 to 36 units – two (2) 3" conduits to each gang base.
  - Two (2) 3" conduits for all road crossings.
12. Uppermost electrical conduit shall have no less than 18" of cover to surface / ground line.



**SECONDARY DITCH  
DETAIL**

DRAWING NUMBER:

2S

REVISED DATE:

APRIL 1, 2024

SCALE: NONE

SHEET: 1 OF 1

# DIMENSIONS FOR CURRENT TRANSFORMER ENCLOSURES

## SCOPE:

The customer shall be responsible for supplying and installing a NEMA 3R enclosure that adheres to the following specifications along with a 1" rigid metal or intermediate conduit connecting the current transformer enclosure with the transformer rated meter socket. Meter socket will be furnished and installed by the customer. Top of meter base will be located between 4 and 6 ft. above final grade. Bottom of the CT cabinet shall be a minimum of 18" above grade, and the top of the CT cabinet shall be a maximum of 72".

## MATERIAL:

The enclosure shall be constructed of aluminum. The aluminum shall be a minimum thickness of nine hundredth (0.090) inches. All bolts, nuts, and washers shall be stainless steel, or aluminum. The backboard shall be 3/4 inches treated, exterior, BB grade plywood. A galvanized steel cabinet with ANSI G1 light duty gray re-coatable powdercoat (electrostatically applied and oven cured) may be substituted for the aluminum box.

## DESIGN:

All joining edges shall have a minimum of one (1) inch overlap. The front of the enclosure shall have a minimum of one (1) inch flange on all sides. The door panel shall be removable with a minimum of one (1) inch flanges on the sides and bottom. The plywood backboard shall be mounted on the inside back of the unit with four stainless steel bolts, nuts, and washers and maintain a minimum of 1/4 inch spacing between the board and cabinet. The enclosure shall be provided with one (1) ground lug. The enclosure shall have a latching handle with provisions for a padmount lock to be connected to secure the enclosure.

## SIZE:

The minimum dimensional requirements for the enclosure are given in the following table.

**TABLE 1**

SERVICE	LENGTH	WIDTH	DEPTH	OPTION
3 PHASE	36 INCHES	36 INCHES	15 INCHES	PREFERRED
1 PHASE	32 INCHES	32 INCHES	15 INCHES	PREFERRED 1-PH

If these measurements can not be met, the length and width may be altered provided the volume of the enclosure is maintained. In no way is the depth of the enclosure to be less than fifteen (15) inches.

NOTE: SEE TABLE 1 FOR ALLOWABLE DIMENSIONS.

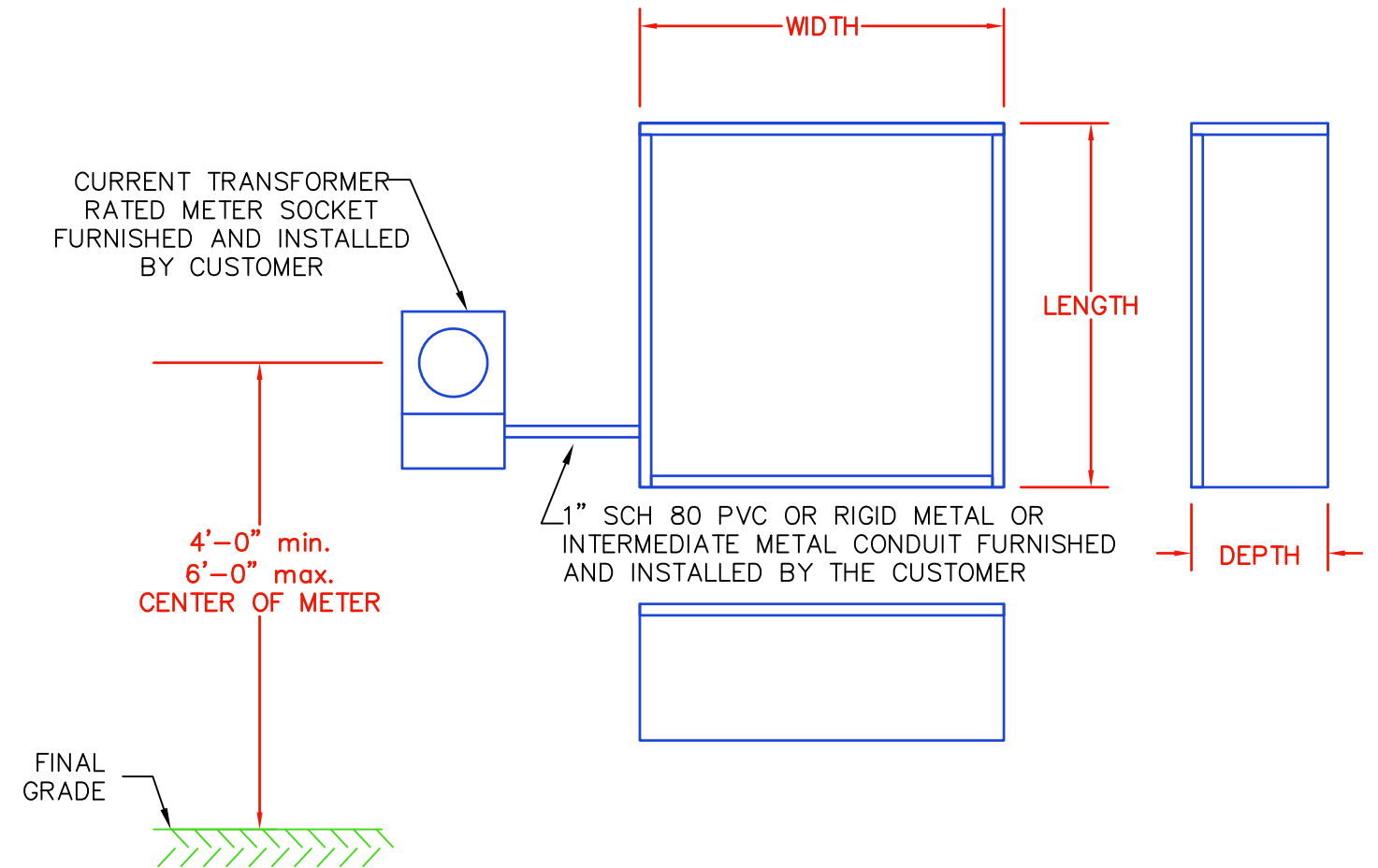

**CURRENT TRANSFORMER ENCLOSURE SPECIFICATIONS**

<b>CTE-1</b>	DRAWING NUMBER:	REVISED DATE:
		JULY 1, 2023
	SCALE: <u>NONE</u>	
SHEET: <u>1</u> OF <u>1</u>		

## **MTE Office Locations**

---

### **WILLIAMSON**

2156 Curd Lane  
Franklin, Tennessee 37067

### **WILSON**

201 Maddox-Simpson Parkway  
Lebanon, Tennessee 37087

### **Mt JULIET**

2722 North Mt. Juliet Road  
Mt. Juliet, Tennessee 37122

### **CANNON**

911 West Main  
Woodbury, Tennessee 37190

### **SMYRNA**

505 Nolan Drive  
Smyrna, Tennessee 37167

### **MURFREESBORO**

810 Commercial Court  
Murfreesboro, Tennessee 37129

### **RUTHERFORD**

326 St. Andrews Drive  
Murfreesboro, Tennessee 37128

### **CENTRAL**

555 New Salem Highway  
Murfreesboro, Tennessee 37129

*Customer Service: 1-877-777-9020*